



DIAMOND SYSTEMS CORPORATION

Emerald-MM-8Plus

PC/104-Plus 8-Port Multi-Protocol Serial Port Module

Rev C: March 2010

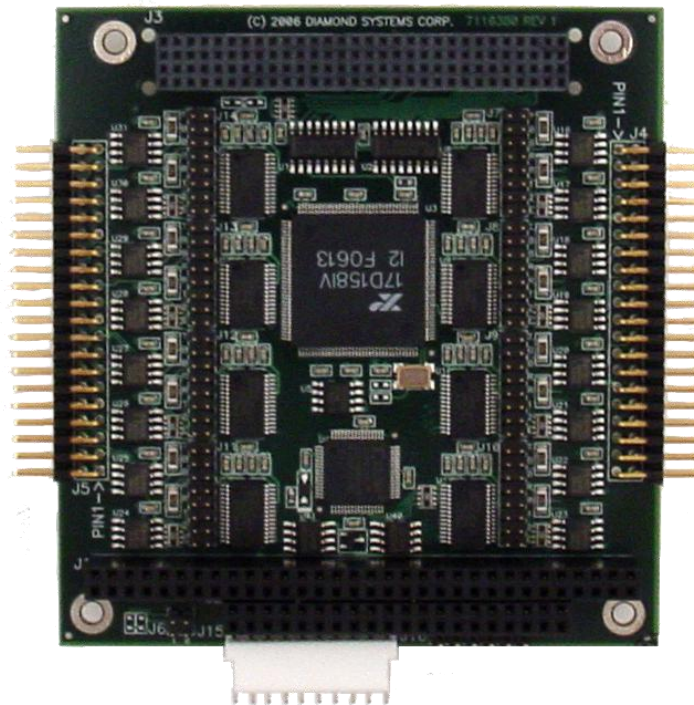

Revision	Date	Comment
B	1/6/2010	Major Update & Reformatting
C	3/8/10	Updates on pages 14-15

FOR TECHNICAL SUPPORT
PLEASE CONTACT:

support@diamondsystems.com

© Copyright 2010
Diamond Systems Corporation
1255 Terra Bella Ave.
Mountain View, CA 94043 USA
Tel 1-650-810-2500
Fax 1-650-810-2525
www.diamondsystems.com

CONTENTS

1. Important Safe Handling Information	3
2. Introduction	5
2.1. Description and Features	5
2.2. Functional Block Diagram	6
2.3. Board Diagram	7
2.4. Connector Summary	8
2.5. Jumper Summary	8
3. Connectors	9
3.1. PC/104 ISA Bus	9
3.2. PC/104-Plus PCI Bus	10
3.3. I/O Header Connectors	11
4. RS-232 Pin Assignment	12
5. RS-485 Pin Assignment	13
6. RS-422 Pin Assignment	14
6.1. Digital I/O and Counter/timer Connector	15
6.2. Board Configuration	16
6.3. Serial Protocol Selection	16
7. RS-232 Selection	17
8. RS-422 Selection	18
9. RS-485 Selection	19
9.1. PCI Slot ID Selection	19
9.2. Digital I/O and Counter/Timer	20
10. Specifications	21
10.1. Serial Ports	21
10.2. Digital I/O	21
10.3. General	21
11. Additional Information	21

FIGURES

Figure 1: EMM-8Plus Functional Block Diagram	6
Figure 2: EMM-8Plus Board Layout	7
Figure 3: PC/104 ISA Bus Connectors - J1, J2	9
Figure 4: PC/104-Plus PCI Connector - J3	10
Figure 5: I/O Header Connectors - J4, J5	11
Figure 6: RS-232 Protocol Selection	17
Figure 7: RS-422 Protocol Selection Options	18
Figure 8: RS-485 Protocol Selection Options	19
Figure 9: PCI Slot ID Selection Jumper	19

1. IMPORTANT SAFE HANDLING INFORMATION



WARNING!

ESD-Sensitive Electronic Equipment

Observe ESD-safe handling procedures when working with this product.

Always use this product in a properly grounded work area and wear appropriate ESD-preventive clothing and/or accessories.

Always store this product in ESD-protective packaging when not in use.

Safe Handling Precautions

The Helios board contains a high number of I/O connectors with connection to sensitive electronic components. This creates many opportunities for accidental damage during handling, installation and connection to other equipment. The list here describes common causes of failure found on boards returned to Diamond Systems for repair. This information is provided as a source of advice to help you prevent damaging your Diamond (or any vendor's) embedded computer boards.

ESD damage – This type of damage is usually almost impossible to detect, because there is no visual sign of failure or damage. The symptom is that the board eventually simply stops working, because some component becomes defective. Usually the failure can be identified and the chip can be replaced.

To prevent ESD damage, always follow proper ESD-prevention practices when handling computer boards.

Damage during handling or storage – On some boards we have noticed physical damage from mishandling. A common observation is that a screwdriver slipped while installing the board, causing a gouge in the PCB surface and cutting signal traces or damaging components.

Another common observation is damaged board corners, indicating the board was dropped. This may or may not cause damage to the circuitry, depending on what is near the corner. Most of our boards are designed with at least 25 mils clearance between the board edge and any component pad, and ground / power planes are at least 20 mils from the edge to avoid possible shorting from this type of damage. However these design rules are not sufficient to prevent damage in all situations.

A third cause of failure is when a metal screwdriver tip slips, or a screw drops onto the board while it is powered on, causing a short between a power pin and a signal pin on a component. This can cause overvoltage / power supply problems described below. To avoid this type of failure, only perform assembly operations when the system is powered off.

Sometimes boards are stored in racks with slots that grip the edge of the board. This is a common practice for board manufacturers. However our boards are generally very dense, and if the board has components very close to the board edge, they can be damaged or even knocked off the board when the board tilts back in the rack. Diamond recommends that all our boards be stored only in individual ESD-safe packaging. If multiple boards are stored together, they should be contained in bins with dividers between boards. Do not pile boards on top of each other or cram too many boards into a small location. This can cause damage to connector pins or fragile components.

Power supply wired backwards – Our power supplies and boards are not designed to withstand a reverse power supply connection. This will destroy each IC that is connected to the power supply (i.e. almost all ICs). In this case the board will most likely will be unrepairable and must be replaced. A chip destroyed by reverse power or by excessive power will often have a visible hole on the top or show some deformation on the top surface due to vaporization inside the package. **Check twice before applying power!**

Board not installed properly in PC/104 stack – A common error is to install a PC/104 board accidentally shifted by 1 row or 1 column. If the board is installed incorrectly, it is possible for power and ground signals on the bus to make contact with the wrong pins on the board, which can damage the board. For example, this can damage components attached to the data bus, because it puts the $\pm 12V$ power supply lines directly on data bus lines.

Overvoltage on analog input – If a voltage applied to an analog input exceeds the design specification of the board, the input multiplexor and/or parts behind it can be damaged. Most of our boards will withstand an erroneous connection of up to $\pm 35V$ on the analog inputs, even when the board is powered off, but not all boards, and not in all conditions.

Overvoltage on analog output – If an analog output is accidentally connected to another output signal or a power supply voltage, the output can be damaged. On most of our boards, a short circuit to ground on an analog output will not cause trouble.

Overvoltage on digital I/O line – If a digital I/O signal is connected to a voltage above the maximum specified voltage, the digital circuitry can be damaged. On most of our boards the acceptable range of voltages connected to digital I/O signals is 0-5V, and they can withstand about 0.5V beyond that (-0.5 to 5.5V) before being damaged. However logic signals at 12V and even 24V are common, and if one of these is connected to a 5V logic chip, the chip will be damaged, and the damage could even extend past that chip to others in the circuit.

Bent connector pins – This type of problem is often only a cosmetic issue and is easily fixed by bending the pins back to their proper shape one at a time with needle-nose pliers. The most common cause of bent connector pins is when a PC/104 board is pulled off the stack by rocking it back and forth left to right, from one end of the connector to the other. As the board is rocked back and forth it pulls out suddenly, and the pins at the end get bent significantly. The same situation can occur when pulling a ribbon cable off of a pin header. If the pins are bent too severely, bending them back can cause them to weaken unacceptably or even break, and the connector must be replaced.

2. INTRODUCTION

Emerald-MM-8Plus is a PC/104-*Plus* module with four or eight serial ports connected through the PCI bus. Each port supports RS-232, RS-422, RS-485 and 5V TTL interfaces using jumper configuration. The board also has eight digital I/O lines and a 16-bit counter/timer.

Emerald-MM-8Plus is connector compatible with the Emerald-MM-8P, Emerald-MM-8M, and Emerald-MM-8232 boards. The board is compatible with any SBC with a PC/104-*Plus* expansion socket and operates with both 3.3V and 5V PCI I/O voltage buses.

2.1 Description and Features

Two I/O headers are provided, with four serial ports on each header. The board operates on +5V only, eliminating the need for a +12V supply that is often required for serial port operation.

Emerald-MM-8Plus is based on the Exar XR17D158IV Octal UART. This device contains eight identical sets of registers, one set for each port. The registers are compatible with the standard PC serial port. Each port contains a 64-byte FIFO.

The Emerald-MM-8Plus has the following features.

- I/O connectors compatible with Emerald-MM-8P (two connectors, 40 pins, four ports per connector).
- Eight serial ports based on Exar XR17D158IV Octal UART with 64-byte FIFOs.
- RS-232, RS-422, RS-485, and TTL interfaces supported: RS-232/422/485 jumper selectable; TTL available as a custom assembly configuration.
- Baud rates to 921.6Kbps in RS-232 or TTL mode, 1.8432Mbps in RS-422/RS-485 modes.
- Jumper-selected protocol and line termination.
- EEPROM storage of configuration data for instant availability on power-up.
- I/O lines are short circuit protected.
- Eight digital I/O lines with 5V logic.
- LED connected to digital I/O line 0.
- Programmable counter/timer with selectable clock source.
- Dual 40-pin I/O headers, 4 ports per header.
- +5V only operation.
- Extended temperature (-40°C to +85°C) operation.
- PC/104-*Plus* form factor.
- Stackthrough PC/104 and PC/104-*Plus* connectors installed.

Refer to the Exar XR17D158IV datasheet, listed in the Additional Information section of this document, for detailed information about using the UART, DIO and EEPROM functionality with the PC/104-*Plus* bus.

2.2 Functional Block Diagram

Figure 1 shows the Emerald-MM-8Plus functional blocks.

Figure 1: EMM-8Plus Functional Block Diagram

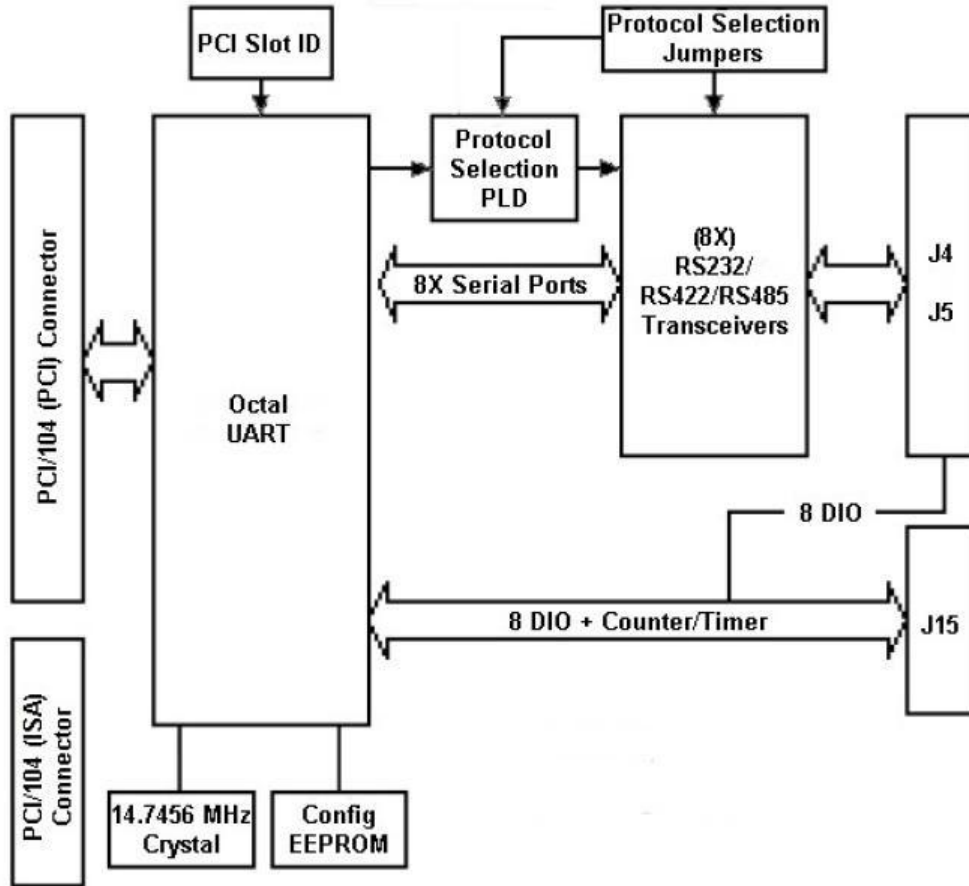

2.3 Board Diagram

Figure 2 shows the Emerald-MM-8Plus board connectors and jumpers.

Figure 2: EMM-8Plus Board Layout

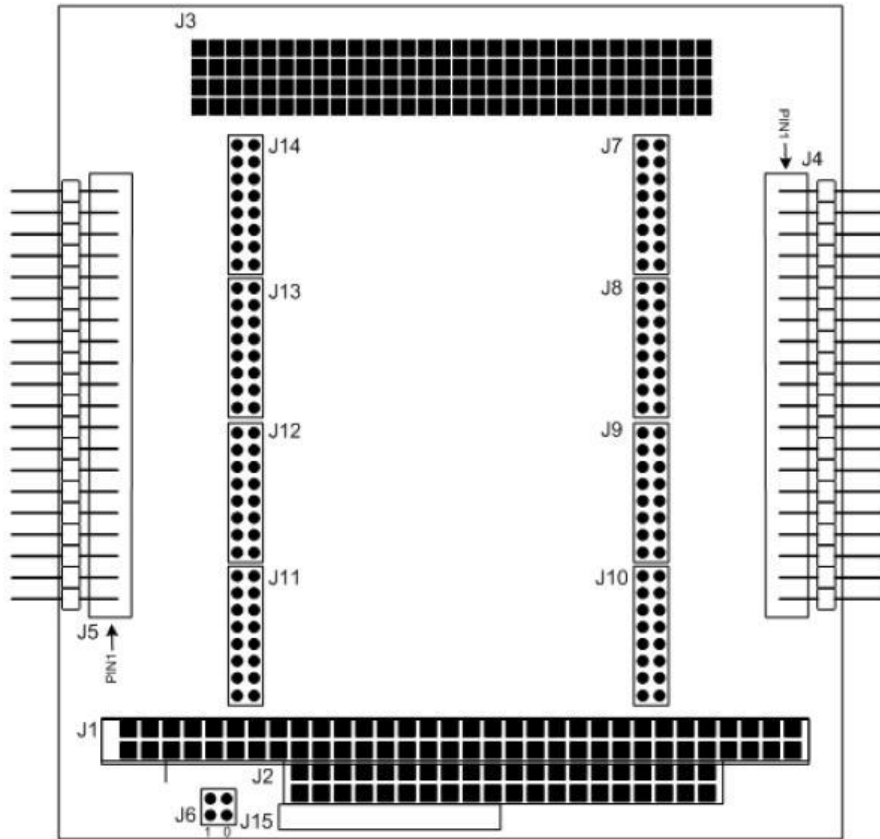

2.4 Connector Summary

The following tables list the Emerald-MM-8Plus board connectors.

Connector	Description	Manufacturer Part Number
J1	PC/104, ISA bus A,B	EPT 962-60323-12
J2	PC/104, ISA bus C,D	EPT 962-60203-12
J3	PC/104-Plus PCI bus connector	
J4	Serial ports 1-4	
J5	Serial ports 5-8	
J15	Digital I/O and counter/timer	

2.5 Jumper Summary

The following table lists the Emerald-MM-8Plus jumpers.

Jumper	Description
J6	PCI bus slot selection
J7-J10	Serial port configuration (Serial ports 1-4, respectively)
J11-J14	Serial port configuration (Serial ports 5-8, respectively)

3. CONNECTORS

This section describes the connectors on the Emerald-MM-8Plus board.

3.1 PC/104 ISA Bus

Connectors J1 and J2 carry the ISA bus signal. Figure 3 shows the PC/104 A and B pin layout for J1, and the C and D pin layout for J2. These signals are not used to communicate with the SBC but are passed to other cards on the PC/104 stack.

Figure 3: PC/104 ISA Bus Connectors - J1, J2

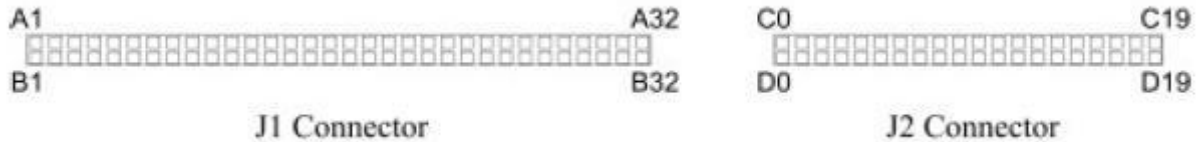

J1 Connector Pinout

IOCHCHK-	A1	B1	GND
SD7	A2	B2	RESETDRV
SD6	A3	B3	+5V
SD5	A4	B4	IRQ9
SD4	A5	B5	-5V
SD3	A6	B6	DRQ2
SD2	A7	B7	-12V
SD1	A8	B8	ENDXFR-
SD0	A9	B9	+12V
IOCHRDY	A10	B10	keyed
AEN	A11	B11	SMEMW-
SA19	A12	B12	SMEMR-
SA18	A13	B13	IOW-
SA17	A14	B14	IOR-
SA16	A15	B15	DACK3-
SA5	A16	B16	DRQ3
SA14	A17	B17	DACK1-
SA13	A18	B18	DRQ1
SA12	A19	B19	REFRESH-
SA11	A20	B20	SYSCLK
SA10	A21	B21	IRQ7
SA9	A22	B22	IRQ6
SA8	A23	B23	IRQ5
SA7	A24	B24	IRQ4
SA6	A25	B25	IRQ3
SA5	A26	B26	DACK2-
SA4	A27	B27	TC
SA3	A28	B28	BALE
SA2	A29	B29	+5V
SA1	A30	B30	OSC
SA0	A31	B31	GND
GND	A32	B32	GND

J2 Connector Pinout

GND	C0	D0	GND
SBHE-	C1	D1	MEMCS16--
LA23	C2	D1	IOCS16-
LA22	C3	D1	IRQ10
LA21	C4	D1	IRQ11
LA20	C5	D1	IRQ12
LA19	C6	D1	IRQ15
LA18	C7	D1	IRQ14
LA17	C8	D1	DACK0-
MEMR-	C9	D1	DRQ0
MEMW-	C10	D1	DACK5-
SD8	C11	D1	DRQ5
SD9	C12	D1	DACK6-
SD10	C13	D1	DRQ6
SD11	C14	D1	DACK7-
SD12	C15	D1	DRQ7
SD13	C16	D1	+5
SD14	C17	D1	MASTER
SD15	C18	D1	GND
keyed	C19	D1	GND

3.2 PC/104-Plus PCI Bus

The PC/104-Plus bus is essentially identical to the PCI Bus except for the physical design. A single pin and socket connector is specified for the bus signals. A 120-pin header, J3, arranged as four 30-pin rows incorporates a full 32-bit, 33MHz PCI Bus. The additional pins on the PC/104-Plus connectors are used as ground or key pins. The female sockets on the top of the board enable stacking another PC/104-Plus board on top of the Emerald-MM-8Plus board. The EMM8-Plus cannot be configured as a PCI bus master.

In the connector J3 pinout table, below, the top corresponds to the left edge of the connector when the board is viewed from the primary side (the side with the female end of the PC/104-Plus connector), and the board is oriented so that the PC/104 connectors are along the bottom edge of the board and the PC/104-Plus connector is in the top of the Emerald-MM-8Plus board.

Figure 4: PC/104-Plus PCI Connector - J3

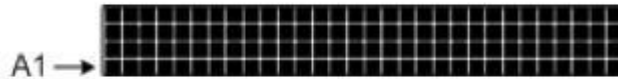

Pin #	A	B	C	D
1	GND/5.0V KEY	Reserved	+5V	AD00
2	VI/O	AD02	AD01	+5V
3	AD05	GND	AD04	AD03
4	C/BE0*	AD07	GND	AD06
5	GND	AD09	AD08	GND
6	AD11	VI/O	AD10	M66EN
7	AD14	AD13	GND	AD12
8	+3.3V	C/BE1*	AD15	+3.3V
9	SERR*	GND	Reserved	PAR
10	GND	PERR*	+3.3V	Reserved
11	STOP*	+3.3V	LOCK*	GND
12	+3.3V	TRDY*	GND	DESEL*
13	FRAME*	GND	IRDY*	+3.3V
14	GND	AD16	+3.3V	C/BE2*
15	AD18	+3.3V	AD17	GND
16	AD21	AD20	GND	AD19
17	+3.3V	AD23	AD22	+3.3V
18	IDSEL0	GND	IDSEL1	IDSEL2
19	AD24	C/BE3*	VI/O	IDSEL3
20	GND	AD26	AD25	GND
21	AD29	+5V	AD28	AD27
22	+5V	AD30	GND	AD31
23	REQ0*	GND	REQ1*	VI/O
24	GND	REQ2*	+5V	GNT0*
25	GNT1*	VI/O	GNT2*	GND
26	+5V	CLK0	GND	CLK1
27	CLK2	+5V	CLK3	GND
28	GND	INTD*	+5V	RST*
29	+12V	INTA*	INTB*	INTC*
30	-12V	-REQ3	-GNT3	GND/3.3V KEY

On the Emerald-MM-8Plus, the octal UART is connected to the PCI bus and is powered by 5V with its PCI interface powered by the PCI bus VIO, which can be 3.3V or 5V. For this reason, the connector is not keyed (to prevent certain types of cards from being inserted).

3.3 I/O Header Connectors

Emerald-MM-8Plus provides two identical 40-pin headers labeled J4 and J5 for the serial ports. Four ports are contained on each header.

Figure 5: I/O Header Connectors - J4, J5

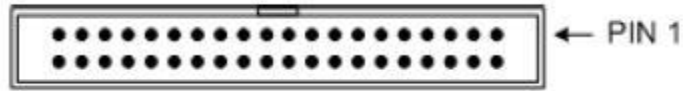

Connector J4 is for ports 1-4 and is located along the right side of the board.

<i>J4 Port Number</i>	<i>Pin Assignment</i>
PORT1	Pins 1 - 10
PORT2	Pins 11 - 20
PORT3	Pins 21 - 30
PORT4	Pins 31 - 40

Connector J5 is for ports 5-8 and is located along the left side of the board.

<i>J5 Port Number</i>	<i>Pin Assignment</i>
PORT5	Pins 1 - 10
PORT6	Pins 11 - 20
PORT7	Pins 21 - 30
PORT8	Pins 31 - 40

Pin numbers are marked on the board to assist with connector orientation.

Cable Assembly Number C-DB9M-4 connects this header to four DE-9 Male connectors for direct connection to RS-232-C signaling. The following tables list the signals for the appropriate mode of operation, as well as the DE-9 pin numbers to which these signals are wired.

4. RS-232 PIN ASSIGNMENT

J4				J5					
Port 1	DCD1	1	2	DSR1	Port 5	DCD5	1	2	DSR5
	RXD1	3	4	RTS1		RXD5	3	4	RTS5
	TXD1	5	6	CTS1		TXD5	5	6	CTS5
	DTR1	7	8	RI1		DTR5	7	8	RI5
	GND	9	10	DIO0		GND	9	10	DIO4
Port 2	DCD2	11	12	DSR2	Port 6	DCD6	11	12	DSR6
	RXD2	13	14	RTS2		RXD6	13	14	RTS6
	TXD2	15	16	CTS2		TXD6	15	16	CTS6
	DTR2	17	18	RI2		DTR6	17	18	RI6
	GND	19	20	DIO1		GND	19	20	DIO5
Port 3	DCD3	21	22	DSR3	Port 7	DCD7	21	22	DSR7
	RXD3	23	24	RTS3		RXD7	23	24	RTS7
	TXD3	25	26	CTS3		TXD7	25	26	CTS7
	DTR3	27	28	RI3		DTR7	27	28	RI7
	GND	29	30	DIO2		GND	29	30	DIO6
Port 4	DCD4	31	32	DSR4	Port 8	DCD8	31	32	DSR8
	RXD4	33	34	RTS4		RXD8	33	34	RTS8
	TXD4	35	36	CTS4		TXD8	35	36	CTS8
	DTR4	37	38	RI4		DTR8	37	38	RI8
	GND	39	40	DIO3		GND	39	40	DIO7

Signal	Definition	DE-9 Pin	Direction
DCD n	Data Carrier Detect	pin 1	Input
DSR n	Data Set Ready	pin 6	Input
RXD n	Receive Data	pin 2	Input
RTS n	Request to Send	pin 7	Output
TXD n	Transmit Data	pin 3	Output
CTS n	Clear to Send	pin 8	Input
DTR n	Data Terminal Ready	pin 4	Output
RI n	Ring Indicator	pin 9	Input
GND	Ground	pin 5	Signal Ground
DIO n	Digital I/O	-	-

5. RS-485 PIN ASSIGNMENT

				J4						J5	
Port 1	NC	1	2	NC	Port 5	NC	1	2	NC		
	TXD/RXD+1	3	4	TXD/RXD-1		TXD/RXD+5	3	4	TXD/RXD-5		
	NC	5	6	NC		NC	5	6	NC		
	NC	7	8	NC		NC	7	8	NC		
	GND	9	10	DIO0		GND	9	10	DIO4		
Port 2	NC	11	12	NC	Port 6	NC	11	12	NC		
	TXD/RXD+2	13	14	TXD/RXD-2		TXD/RXD+6	13	14	TXD/RXD-6		
	NC	15	16	NC		NC	15	16	NC		
	NC	17	18	NC		NC	17	18	NC		
	GND	19	20	DIO1		GND	19	20	DIO5		
Port 3	NC	21	22	NC	Port 7	NC	21	22	NC		
	TXD/RXD+3	23	24	TXD/RXD-3		TXD/RXD+7	23	24	TXD/RXD-7		
	NC	25	26	NC		NC	25	26	NC		
	NC	27	28	NC		NC	27	28	NC		
	GND	29	30	DIO2		GND	29	30	DIO6		
Port 4	NC	31	32	NC	Port 8	NC	31	32	NC		
	TXD/RXD+4	33	34	TXD/RXD-4		TXD/RXD+8	33	34	TXD/RXD-8		
	NC	35	36	NC		NC	35	36	NC		
	NC	37	38	NC		NC	37	38	NC		
	GND	39	40	DIO3		GND	39	40	DIO7		

Signal	Definition	DE-9 Pin	Direction
TXD/RXD+ <i>n</i>	Differential Transceiver Data (HIGH)	pin 2	bi-directional
TXD/RXD- <i>n</i>	Differential Transceiver Data (LOW)	pin 7	bi-directional
GND	Ground	pin 5	Signal Ground
NC	(not connected)	-	-
DIO <i>n</i>	Digital I/O	-	-

6. RS-422 PIN ASSIGNMENT

		J4				J5			
Port 1	NC	1	2	NC	Port 5	NC	1	2	NC
	TXD+1	3	4	TXD-1		TXD+5	3	4	TXD-5
	NC	5	6	RXD-1		NC	5	6	RXD-5
	RXD+1	7	8	NC		RXD+5	7	8	NC
	GND	9	10	DIO0		GND	9	10	DIO4
Port 2	NC	11	12	NC	Port 6	NC	11	12	NC
	TXD+2	13	14	TXD-2		TXD+6	13	14	TXD-6
	NC	15	16	RXD-2		NC	15	16	RXD-6
	RXD+2	17	18	NC		RXD+6	17	18	NC
	GND	19	20	DIO1		GND	19	20	DIO5
Port 3	NC	21	22	NC	Port 7	NC	21	22	NC
	TXD+3	23	24	TXD-3		TXD+7	23	24	TXD-7
	NC	25	26	RXD-3		NC	25	26	RXD-7
	RXD+3	27	28	NC		RXD+7	27	28	NC
	GND	29	30	DIO2		GND	29	30	DIO6
Port 4	NC	31	32	NC	Port 8	NC	31	32	NC
	TXD+4	33	34	TXD-4		TXD+8	33	34	TXD-8
	NC	35	36	RXD-4		NC	35	36	RXD-8
	RXD+4	37	38	NC		RXD+8	37	38	NC
	GND	39	40	DIO3		GND	39	40	DIO7

Signal	Definition	DE-9 Pin	Direction
TXD+n/TXD-n	Differential transmit data	pin 2/pin 7	Output*
RXD+n/RXD-n	Differential receive data	pin 4/pin 8	Input*
GND	Ground	pin 5	Signal Ground
NC	(not connected)	-	-
DIO _n	Digital I/O	-	-

6.1 Digital I/O and Counter/timer Connector

Connector J15 is a 1x10, single-row, right-angle connector that provides the following digital I/O and counter/timer signals.

1	DIO 7
2	DIO 6
3	DIO 5
4	DIO 4
5	DIO 3
6	DIO 2
7	DIO 1
8	DIO 0/Counter/timer Out/LED Out
9	Counter/timer In
10	GND

Signal	Definition
DIO 0-7	Digital I/O; programmable direction
Counter/timer In	Counter/timer input
Counter/timer Out	Counter/timer output
LED Out	User-defined LED, typically for board status
GND	Ground

The DIO/Counter connector J15 provides access to 8 UART DIO lines. These same lines are available on the port connectors J4 and J5. Users should be aware that the DIO on the serial port connectors and J15 are the same line.

6.2 Board Configuration

The board provides jumper blocks to configure the following functions.

- Serial port protocol RS-232/422/485/TTL: 2 positions for each port.
- RS-422/485 RX and TX termination: 4 positions for each port.
- RS-485 echo yes/no per port: 1 position for each port.
- PCI slot ID: 2 positions for slot 0-3 selection.

For hardwired configuration, locations are provided on the PCB for 0-ohm resistors to be installed to replace each valid jumper position.

6.3 Serial Protocol Selection

Jumper blocks J7 through J14 are used to select the protocol for each serial port, as shown in the table below. Each jumper block configures one port, and each port may have its protocol set independently of the other ports.

<i>Jumper</i>	<i>Port</i>
J7	1
J8	2
J9	3
J10	4
J11	5
J12	6
J13	7
J14	8

In RS-422 or RS-485 networks, termination resistors are normally installed at the endpoints of the cables to minimize reflections on the lines. Emerald-MM-8Plus provides 150Ω resistors for this purpose. To enable resistor termination for a port, install jumpers in the locations *T* and *R* of that port's corresponding configuration jumper block as shown, below.

Note: Termination is only needed, and should only be used, at the cable endpoints. Enabling these termination resistors at each end of the cable results in an effective impedance of 60Ω. Installing termination resistors at additional points in the network may cause overloading and failure of the line drivers due to the lower impedance caused by multiple resistors in parallel.

In RS-422 or RS-485 networks, biasing resistors are normally installed at the endpoints of the cables to force a known inactive state on the lines to reduce noise and eliminate line float by pulling the Data+ line to +5V and the Data- line to ground. Emerald-MM-8Plus provides 4.7KΩ resistors for this purpose. To enable resistor termination for a port, install jumpers in the locations *B* of that port's corresponding configuration jumper block as shown above. For RS-422 networks the RX termination always has biasing resistors connected when used and the TX termination has the biasing resistor connections optional when used.

Note: Biasing is only needed, and should only be used, at one of the cable endpoints. Installing biasing resistors at additional points in the network may cause overloading and failure of the line drivers due to the lower impedance caused by multiple resistors in parallel.

7. RS-232 SELECTION

Figure 6 shows the J7 through J14 jumper settings to select the RS-232 protocol. (No pins are jumpered).

Figure 6: RS-232 Protocol Selection

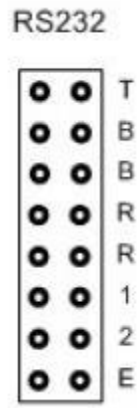

8. RS-422 SELECTION

Figure 7 shows the J7 through J14 jumper settings to select the RS-422 protocol options.

Figure 7: RS-422 Protocol Selection Options

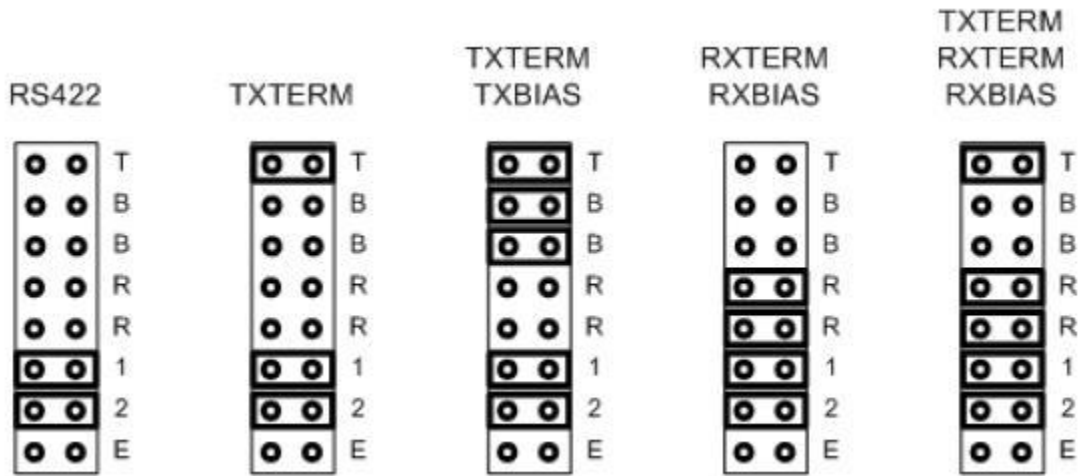

9. RS-485 SELECTION

Figure 8 shows the J7 through J14 jumper settings to select the RS-485 protocol options.

Figure 8: RS-485 Protocol Selection Options

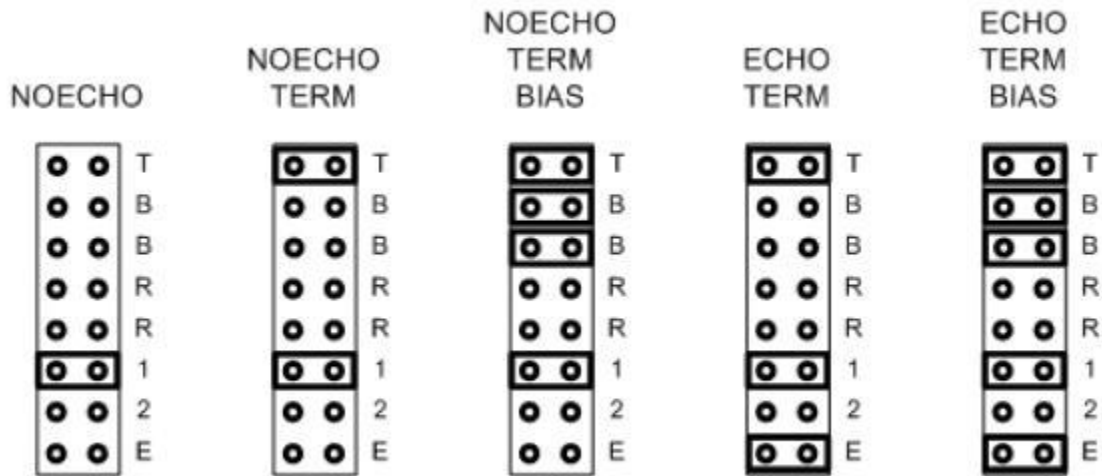

9.1 PCI Slot ID Selection

Jumper block J6 sets the PCI slot ID using two jumpers, as shown in Figure 9. Take care in selecting the correct PCI slot to avoid resource conflicts in the software driver.

Figure 9: PCI Slot ID Selection Jumper

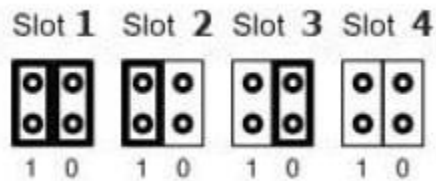

9.2 Digital I/O and Counter/Timer

The XR17D158 UART offers 8 built-in digital I/O lines and a programmable counter/timer. The 8 DIO lines and the counter/timer signals are brought out to an 8-pin connector on the lower edge of the board.

The DIO and counter/timer signals are 3.3V nominal logic signals and have ESD protection.

The 8 DIO lines are also available on the 8 extra pins on the two serial I/O connectors to provide compatibility with EMM-8P. The user must be made aware of the limitation that only one source can be used for input, either the serial port connector or the dedicated DIO connector.

The counter/timer's output is multiplexed under software control to DIO 0. The counter/timer's input is programmable for either an internal clock or an external signal. The external signal is available on a pin on the digital I/O connector.

DIO 0 has an LED connected to it for use in displaying board activity or health status.

10. SPECIFICATIONS

10.1 Serial Ports

- Number of serial ports: 8
- Protocols: RS-232, RS-422, RS-485
- Maximum baud rate: 921.6Kbps (RS-232), 1.832Mbps (RS-422/RS-485)
- Communications parameters: 5, 6, 7, or 8 data bits; even, odd, or no parity
- Short circuit protection: All outputs protected against continuous short circuit

RS-232 mode

- Input impedance: 3K Ω min
- Input voltage swing: $\pm 30V$ max
- Display type: $\pm 5V$ min, $\pm 7V$ typical

RS-422/RS-485 modes

- Differential input threshold: -0.2V min, +0.2V max
- Input impedance: 12K Ω min
- Input current: +1.0mA max (VIN = 12V)
-0.8mA max (VIN = -7V)
- Differential output voltage: 2.0V min (RL = 50 Ω)
- High/low states differential output voltage symmetries: 0.2V max

10.2 Digital I/O

- Number of I/O lines: 8 in, 8 out
- Input voltage: Low: -0.3V min, 0.8V max
High: 2.0V min, 5.3V max
- Output voltage: Low: 0.0V min, 0.4V max (IOL = 6mA max)
High: 3.7V min, 5.0V max (IOH = -4mA max)

10.3 General

- Dimensions: 3.55" x 3.775" LxW (PC/104 standard)
- Power supply: +5VDC $\pm 10\%$
- Current consumption: 160mA typical, all outputs unloaded
- Operating temperature: -40°C to +85°C
- Operating humidity: 5% to 95% non-condensing
- PC/104 bus: 8-bit and 16-bit bus headers are installed and used (16-bit header is used for interrupt levels only)
- I/O header: 2 40-position (2x20) .025" square pin header on .1" centers;
Headers mate with standard ribbon cable (IDC) connectors.

11. ADDITIONAL INFORMATION

Additional information can be found at the following web links.

Universal PCI Bus Octal UART (XR17D158 Datasheet:
<http://www.exar.com/Files/Documents/xr17d158-122-081005.pdf>,
Exar Corporation, August 2005.