



DIAMOND SYSTEMS CORPORATION

FP-GPIO96

FeaturePak™ I/O Module with 96 Digital I/O Points

Rev A January 2011



Revision	Date	Comment
A	1/17/11	Initial version

**FOR TECHNICAL SUPPORT
PLEASE CONTACT:**

support@diamondsystems.com

© Copyright 2011
Diamond Systems Corporation
1255 Terra Bella Ave.
Mountain View, CA 94043 USA
Tel 1-650-810-2500
Fax 1-650-810-2525
www.diamondsystems.com

CONTENTS

Important Safe Handling Information	3
1. Introduction	4
1.1 Description	4
1.2 Features	4
1.3 FeaturePak Resources	5
2. Functional Overview	6
2.1 Functional Block Diagram	6
2.2 Board Drawing	7
3. Connector Pinout and Pin Description	8
3.1 FeaturePak Connector	8
3.1.1 PCI Express	8
3.1.2 System Interface Signals	8
3.2 FeaturePak Connector Pinout	9
3.3 Digital I/O Signals	10
4. Theory of Operation	11
4.1 DIO Blocks	11
4.2 Counter/Timer and PWM Block	11
4.3 Interrupts	11
5. Board Configuration	12
5.1 Configuring Using Universal Driver	12
5.2 Configuring Using Register Operations	12
5.2.1 Interrupt level	12
6. I/O Registers	13
6.1 I/O Map Summary	13
6.2 I/O Register Details	14
6.2.1 BAR0 + 32 (0x20) DIO Block A Registers	15
6.2.2 BAR0 + 32 (0x20) DIO Block B Registers	19
6.2.3 BAR0 + 48 (0x30) Counters, PWM Block Registers	22
6.2.4 BAR0 + 112 (0x70) Interrupts, Miscellaneous, and ID Block Registers	28
6.2.5 BAR0 + 224 (0xE0) SPI Flash Interface Block Registers	33
7. Digital I/O Operation	36
7.1 Digital I/O Configuration Register	37
7.2 Outputting data to a DIO port	37
7.3 Reading data from a DIO port	38
8. Counter/Timer Operation	38
8.1 Counter/Timer Features and Configuration Options	38
8.2 Counter/Timer Configuration	39
8.3 Counter/Timer Access and Programming	39
8.3.1 Counter/Timer commands	40
8.4 Timer interrupts	43
9. PWM Operation	44
10. Specifications	45

IMPORTANT SAFE HANDLING INFORMATION



WARNING!

ESD-Sensitive Electronic Equipment

Observe ESD-safe handling procedures when working with this product.

Always use this product in a properly grounded work area and wear appropriate ESD-preventive clothing and/or accessories.

Always store this product in ESD-protective packaging when not in use.

Safe Handling Precautions

The FP-GPIO96 board contains a high density connector with many connections to sensitive electronic components. This creates many opportunities for accidental damage during handling, installation and connection to other equipment. The list here describes common causes of failure found on boards returned to Diamond Systems for repair. This information is provided as a source of advice to help you prevent damaging your Diamond (or any vendor's) embedded computer boards.

ESD damage – This type of damage is usually almost impossible to detect, because there is no visual sign of failure or damage. The symptom is that the board eventually simply stops working, because some component becomes defective. Usually the failure can be identified and the chip can be replaced. To prevent ESD damage, always follow proper ESD-prevention practices when handling computer boards.

Damage during handling or storage – On some boards we have noticed physical damage from mishandling. A common observation is that a screwdriver slipped while installing the board, causing a gouge in the PCB surface and cutting signal traces or damaging components.

Another common observation is damaged board corners, indicating the board was dropped. This may or may not cause damage to the circuitry, depending on what is near the corner. Most of our boards are designed with at least 25 mils clearance between the board edge and any component pad, and ground / power planes are at least 20 mils from the edge to avoid possible shorting from this type of damage. However these design rules are not sufficient to prevent damage in all situations.

A third cause of failure is when a metal screwdriver tip slips, or a screw drops onto the board while it is powered on, causing a short between a power pin and a signal pin on a component. This can cause overvoltage / power supply problems described below. To avoid this type of failure, only perform assembly operations when the system is powered off.

Sometimes boards are stored in racks with slots that grip the edge of the board. This is a common practice for board manufacturers. However our boards are generally very dense, and if the board has components very close to the board edge, they can be damaged or even knocked off the board when the board tilts back in the rack. Diamond recommends that all our boards be stored only in individual ESD-safe packaging. If multiple boards are stored together, they should be contained in bins with dividers between boards. Do not pile boards on top of each other or cram too many boards into a small location. This can cause damage to connector pins or fragile components.

Power supply wired backwards – Our power supplies and boards are not designed to withstand a reverse power supply connection. This will destroy each IC that is connected to the power supply (i.e. almost all ICs). In this case the board will most likely will be unreparable and must be replaced. A chip destroyed by reverse power or by excessive power will often have a visible hole on the top or show some deformation on the top surface due to vaporization inside the package. **Check twice before applying power!**

Overvoltage on digital I/O line – If a digital I/O signal is connected to a voltage above the maximum specified voltage, the digital circuitry can be damaged. On most of our boards the acceptable range of voltages connected to digital I/O signals is 0-5V, and they can withstand about 0.5V beyond that (-0.5 to 5.5V) before being damaged. However logic signals at 12V and even 24V are common, and if one of these is connected to a 5V logic chip, the chip will be damaged, and the damage could even extend past that chip to others in the circuit

1. INTRODUCTION

1.1 Description

FP-GPIO96 is a general purpose I/O FeaturePak™ module using a high-capacity (700K gate equivalent) PCI Express FPGA for maximum density and flexibility. The base hardware configuration features 96 digital I/O lines grouped into 12 8-bit ports. All ports have I/O buffers to protect the FPGA and offers 3.3V logic drive levels. The ports are organized into a combination of byte-wide, nibble-wide, and bit-wide direction control for maximum flexibility and application compatibility.

The built-in FPGA personality provides multiple configuration options. All 96 I/O lines may be used in common I/O mode. Six of these ports can be reconfigured to enable an array of additional features, including 8 32-bit up/down counter/timers with programmable input source and gate, 4 24-bit PWM circuits with 0-100% duty cycle capability, and interrupt/latched mode operation.

1.2 Features

Digital I/O

- ◆ 96 total I/O lines brought out to the FeaturePak connector
 - 48 I/O lines on the primary I/O connector with 3 8-bit buffers and 2 4-bit buffers for increased direction configuration flexibility
 - 48 I/O lines on the secondary I/O connector with 6 8-bit buffers
- ◆ Configurable digital I/O pull-up/down resistors, each I/O group independently configurable
- ◆ Byte-wide, nibble-wide and bit-wide port direction control

Counter/Timers and Triggering

- ◆ 8 32-bit counter/timers for timing and general purpose use
- ◆ 4 24-bit pulse-width modulator circuits

Miscellaneous

- ◆ One PCI Express x1 lane host interface
- ◆ +3.3VDC input voltage
- ◆ FeaturePak form-factor compliant
- ◆ Zero height expansion module
- ◆ -40°C to +85°C operating temperature
- ◆ Universal Driver software support

1.3 FeaturePak Resources

The following table identifies which resources among those defined by the FeaturePak specification that are used in this product:

 Module Resources	
Company: Diamond Systems Corp.	
Product: FP-GPIO96	
Host Interface Resources Supported	
PCIe x1 links	1
USB channels	–
Serial port	–
SMBus	–
PCIe Reset	√
Sys Reset	√
JTAG	√
+3.3V	√
+5V	√
+12V	–
Notes: www.featurepak.org/label	

2. FUNCTIONAL OVERVIEW

2.1 Functional Block Diagram

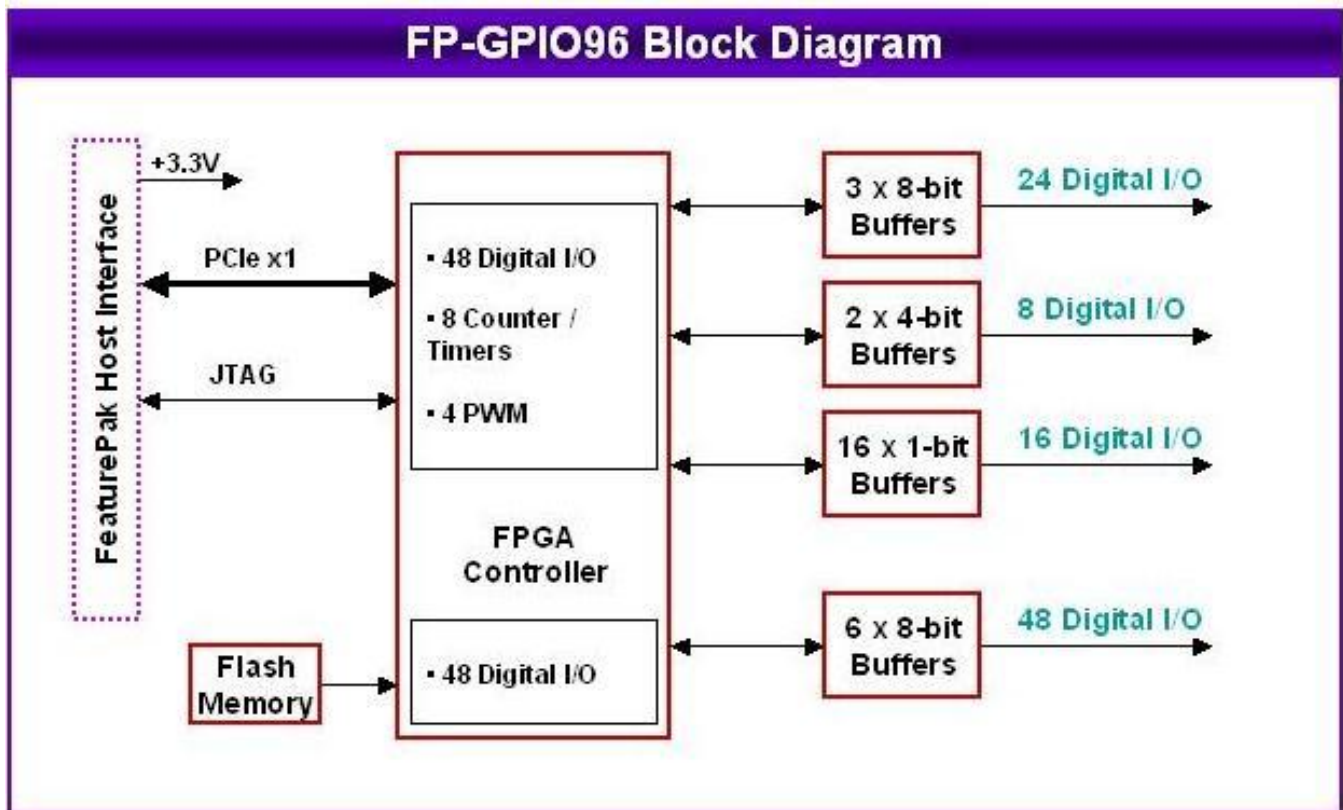

2.2 Board Drawing

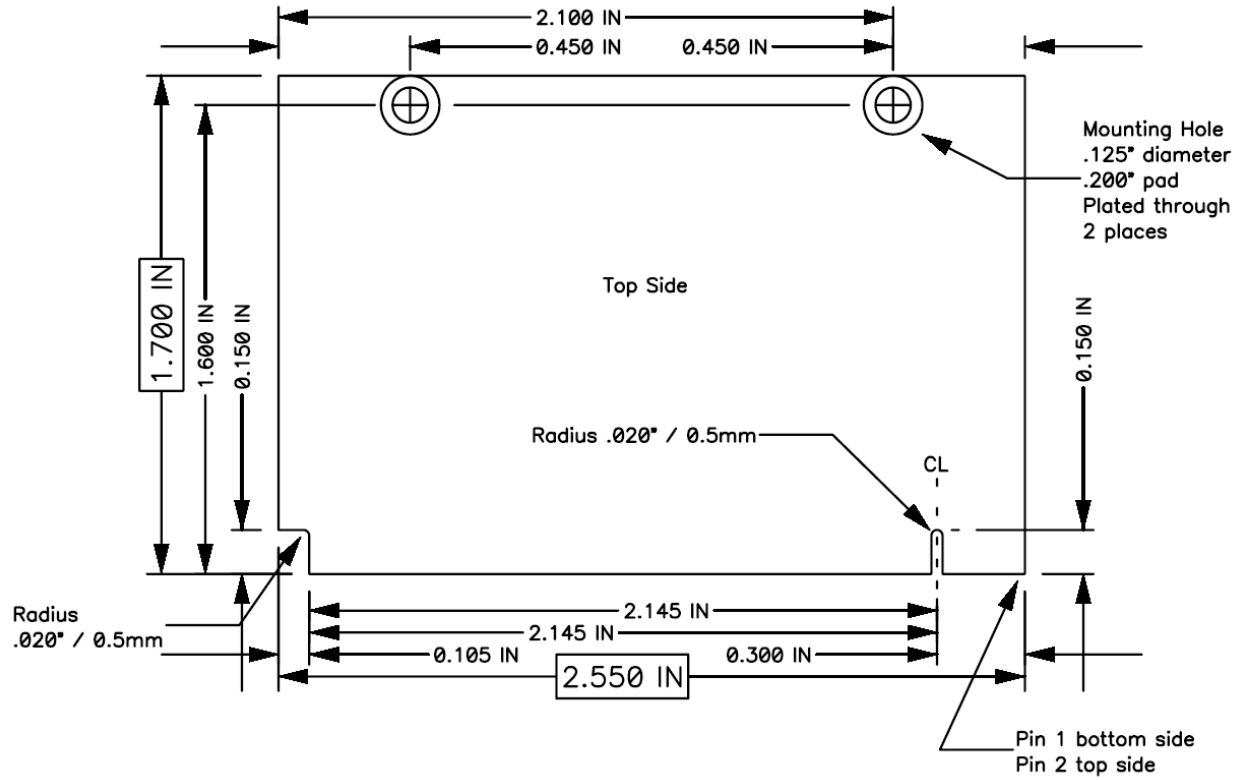

3. CONNECTOR PINOUT AND PIN DESCRIPTION

3.1 FeaturePak Connector

The FP-GPIO96 uses the FeaturePak standard, which provides a card form-factor and connector suitable for high-density, compact applications. See <http://featurepak.org/> for further details of the FeaturePak embedded I/O modules standard, including the specification.

In this document we will use the terms FeaturePak edge card connector and MXM connector interchangeably.

The FP-GPIO96 uses an MXM 230-pin connector for all I/O, both to the main computer and for user I/O connections. The board contains gold-plated fingers conforming to the MXM physical standard for interfacing to the MXM connector.

The system interface signals on the MXM connector are predefined for all FeaturePak modules and a portion of pins are reserved for individual module I/O and are freely assignable for each module. Signals are grouped into several categories:

- ◆ System interface (PCIe)
- ◆ Slot/card management signals
- ◆ Dedicated user I/O
- ◆ Power/ground
- ◆ Reserved for future expansion

The module connects to five reserved pins to provide compatibility with possible future expansion of the FeaturePak standard.

The user I/O consists of 100 signals organized as 2 50-pin groups. On a general purpose baseboard, these signals directly drive 2 50-pin I/O connectors. The 50-pin connectors may then be connected to application-specific cabling, or an I/O adapter board may be plugged onto them to provide a custom I/O connector configuration for the system enclosure. A custom or application-specific main board may elect to use these signals in any way desired without conflicting with the standard.

A special feature of the FeaturePak I/O pin assignment is the electrical isolation provided on 32 of the module I/O pins on the primary 50-pin connector. These pins are separated from each other and from other connector pins by 34 unassigned pins (marked NC) which are to be left unconnected on the main board (no pads or traces leading to these pins). The module omits the corresponding fingers on the edge connector.

3.1.1 PCI Express

The FP-GPIO96 uses a single PCI Express x1 link for its host interface and does not use the USB or serial interfaces allowed in the FeaturePak specification. It is reset by the PCI-Reset- input signal. The module routes the Slot ID signals to a register for readback by the host, and it drives the Present- output line low.

3.1.2 System Interface Signals

Not all functionalities that are defined in the FeaturePak socket standard are supported by the FP-GPIO96 module. For example, the USB, SMBus and serial port interfaces are not utilized on this card.

3.2 FeaturePak Connector Pinout

This section indicates standard FeaturePak connector signal assignments. The I/OA and I/OB pin groups are mapped to specific I/O functions implemented by the FP-GPIO96 board, as indicated in following sections.

	Pins 1 – 114		
+3.3V	1	2	+12V
+3.3V	3	4	PS-Current
Ground	5	6	Ground
PCIe-TX1+	7	8	PCIe-RX1+
PCIe-TX1-	9	10	PCIe-RX1-
Ground	11	12	Ground
PCIe-CLK1+	13	14	PCIe-CLK2+
PCIe-CLK1-	15	16	PCIe-CLK2-
Ground	17	18	Ground
PCIe-TX2+	19	20	PCIe-RX2+
PCIe-TX2-	21	22	PCIe-RX2-
Ground	23	24	Ground
PCIe-Reset-	25	26	Reserved
Reserved	27	28	Reserved
Reserved	29	30	Reserved
Reserved	31	32	Reserved
Reserved	33	34	Reserved
Ground	35	36	Ground
USB-Ch1+	37	38	USB-Ch2+
USB-Ch1-	39	40	USB-Ch2-
Ground	41	42	Ground
+3.3V	43	44	USB-OC1/2-
+3.3V	45	46	Serial-RX1
Serial-TX1	47	48	Serial-CTS1
Serial-RTS1	49	50	SMBclk
SMBAlert#	51	52	SMBdata
Slot ID 2	53	54	Slot ID 1
Slot ID 0	55	56	Present-
JTAG-TDI	57	58	JTAG-TDO
JTAG-CLK	59	60	JTAG-TMS
Sys-Reset-	61	62	Reserved
+3.3V	63	64	Ground
+3.3V	65	66	Ground
Reserved	67	68	Reserved
Reserved	69	70	Reserved
+3.3V	71	72	Ground
Reserved	73	74	Reserved
Reserved	75	76	Reserved
+3.3V	77	78	Ground
Reserved	79	80	Reserved
Reserved	81	82	Reserved
Reserved	83	84	Reserved
Reserved	85	86	Reserved
+5V	87	88	Ground
+5V	89	90	Ground
(Ground) I/OB-50	91	92	I/OB-49 (+3.3V)
I/OB-48	93	94	I/OB-47
I/OB-46	95	96	I/OB-45
I/OB-44	97	98	I/OB-43
I/OB-42	99	100	I/OB-41
I/OB-40	101	102	I/OB-39
I/OB-38	103	104	I/OB-37
I/OB-36	105	106	I/OB-35
I/OB-34	107	108	I/OB-33
I/OB-32	109	110	I/OB-31
I/OB-30	111	112	I/OB-29
I/OB-28	113	114	I/OB-27

	Pin 115 – 230		
I/OB-26	115	116	I/OB-25
I/OB-24	117	118	I/OB-23
I/OB-22	119	120	I/OB-21
I/OB-20	121	122	I/OB-19
I/OB-18	123	124	I/OB-17
I/OB-16	125	126	I/OB-15
I/OB-14	127	128	I/OB-13
I/OB-12	129	130	I/OB-11
I/OB-10	131	132	I/OB-9
I/OB-8	133	134	I/OB-7
I/OB-6	135	136	I/OB-5
I/OB-4	137	138	I/OB-3
I/OB-2	139	140	I/OB-1
+5V	141	142	Ground
+5V	143	144	Ground
+5V	145	146	Ground
(Ground) I/OA-50	147	148	I/OA-49 (+3.3V)
I/OA-48	149	150	I/OA-47
I/OA-46	151	152	I/OA-45
I/OA-44	153	154	I/OA-43
I/OA-42	155	156	I/OA-41
I/OA-40	157	158	I/OA-39
I/OA-38	159	160	I/OA-37
I/OA-36	161	162	I/OA-35
(NC)	163	164	(NC)
I/OA-34	165	166	I/OA-33
(NC)	167	168	(NC)
I/OA-32	169	170	I/OA-31
(NC)	171	172	(NC)
I/OA-30	173	174	I/OA-29
(NC)	175	176	(NC)
I/OA-28	177	178	I/OA-27
(NC)	179	180	(NC)
I/OA-26	181	182	I/OA-25
(NC)	183	184	(NC)
I/OA-24	185	186	I/OA-23
(NC)	187	188	(NC)
I/OA-22	189	190	I/OA-21
(NC)	191	192	(NC)
I/OA-20	193	194	I/OA-19
(NC)	195	196	(NC)
I/OA-18	197	198	I/OA-17
(NC)	199	200	(NC)
I/OA-16	201	202	I/OA-15
(NC)	203	204	(NC)
I/OA-14	205	206	I/OA-13
(NC)	207	208	(NC)
I/OA-12	209	210	I/OA-11
(NC)	211	212	(NC)
I/OA-10	213	214	I/OA-9
(NC)	215	216	(NC)
I/OA-8	217	218	I/OA-7
(NC)	219	220	(NC)
I/OA-6	221	222	I/OA-5
(NC)	223	224	(NC)
I/OA-4	225	226	I/OA-3
(NC)	227	228	(NC)
I/OA-2	229	230	I/OA-1

3.3 Digital I/O Signals

The FP-GPIO96's digital I/O signals are brought out on FeaturePak connector pins 91 through 140, as shown here.

FeaturePak connector pin no. Typical I/O connector pin no. FeaturePak connector pin no.

140	CTR0 IN / DIO A0	1	2	DIO A1 / CTR0 GAT	139
138	CTR1 IN / DIO A2	3	4	DIO A3 / CTR1 GAT	137
136	CTR2 IN / DIO A4	5	6	DIO A5 / CTR2 GAT	135
134	CTR3 IN / DIO A6	7	8	DIO A7 / CTR3 GAT	133
132	CTR4 IN / DIO B0	9	10	DIO B1 / CTR4 GAT	131
130	CTR5 IN / DIO B2	11	12	DIO B3 / CTR5 GAT	129
128	CTR6 IN / DIO B4	13	14	DIO B5 / CTR6 GAT	127
126	CTR7 IN / DIO B6	15	16	DIO B7 / CTR7 GAT	125
124	CTR0 OUT / DIO C0	17	18	DIO C1 / CTR1 OUT	123
122	CTR2 OUT / DIO C2	19	20	DIO C3 / CTR3 OUT	121
120	CTR4 OUT / DIO C4	21	22	DIO C5 / CTR5 OUT	119
118	CTR6 OUT / DIO C6	23	24	DIO C7 / CTR7 OUT	117
116	DIO D0	25	26	DIO D1	115
114	DIO D2	27	28	DIO D3	113
112	DIO D4	29	30	DIO D5	111
110	DIO D6	31	32	DIO D7	109
108	DIO E0	33	34	DIO E1	107
106	DIO E2	35	36	DIO E3	105
104	DIO E4	37	38	DIO E5	103
102	DIO E6	39	40	DIO E7	101
100	PWM0 / DIO F0	41	42	DIO F1 / PWM1	99
98	PWM2 / DIO F2	43	44	DIO F3 / PWM3	97
96	WDT IN / DIO F4	45	46	DIO F5 / WDT OUT	95
94	DIO F6	47	48	DIO F7	93
92	+3.3V	49	50	Dground	91

Signal Name	Definition
DIO A7-A0	Digital I/O port A; byte direction programmable
DIO B7-B0	Digital I/O port B; byte direction programmable
DIO C7-C0	Digital I/O port C; nibble direction programmable
DIO D7-D0	Digital I/O port D; byte direction programmable
DIO E7-E0	Digital I/O port E; bit direction programmable
DIO F7-F0	Digital I/O port F; bit direction programmable
PWM0-3	Port F signals have auxiliary functions enabled with control registers: 32-bit programmable pulse width modulation outputs
Latch- / Ack-	DIO latch and acknowledge signals to enable DIO with handshaking; Latch- also serves as a digital input signal to drive a user-controlled interrupt.
Dground	Digital ground

4. THEORY OF OPERATION

This chapter provides an orientation to the functional architecture of blocks on the board. Additional details are in the register programming section and specific chapters on various blocks.

4.1 DIO Blocks

The FP-GPIO96 has twelve 8-bit bidirectional digital I/O ports, named A-F and G-M. The DIO blocks are controlled and configured using registers at BAR0+32 to 47 for ports A-F and BAR0+96 to 111 for ports G-M.

Ports A, B, D, and G-M are 8-bit ports with direction programmable byte by byte. Register bits DIR[A,B,D,G-M] control the direction of these ports and also the direction of the port pins where a value of 0 = input and 1 = output. In output mode, the values in these registers drive their associated I/O pins. The logic levels on the I/O pins may be read back in both input and output modes. These ports reset to 0 and input mode during power-up, reset, FPGARST=1, or BRDRST=1. If a port is in input mode, its output register may still be written to. When the port is switched to output mode, the value of the output register will drive the corresponding I/O pins.

Port C is divided into two 4-bit nibbles with independent direction control. DIRCH controls the direction of DIOC7-4, and DIRCL controls the direction of DIOC3-0.

Ports E-F are 8-bit ports with direction programmable bit by bit according to register bits DIRE7-0 and DIRF7-0 where a value of 0 = input, 1 = output. I/O pins DIOF3-0 may be reassigned as PWM outputs; see the PWM block description.

Ports A, B, C, and F may be reassigned as counter/timer, PWM, and watchdog timer I/O pins; see the following sections.

4.2 Counter/Timer and PWM Block

The FP-GPIO96 contains 8 32-bit up/down counter timers and 4 PWM generators.

The counter timers have programmable functions that are controlled and configured using registers at BAR0+48 to 55. The counter timers can be used to generate interrupts on the PCI Express bus. For details see sections on Interrupt registers and Chapter 7.2. The counters are programmed using a command register at address 5 in the counter block, a counter number register at address 4, and a 32-bit data register CTRD31-0 at addresses 0-3.

There are four independent 24-bit PWM generators that are controlled and configured using registers at BAR0+56 to 59. The PWM generators are programmed using a register at address 11 for command and PWM number and a 24-bit data register PWMD23-0 at addresses 8-10.

4.3 Interrupts

Interrupts to the PCI Express Bus can be generated by any of these blocks: DIO, or the counter timers 0-3.

Register control is provided for enabling/disabling interrupts by using registers at BAR0+112 and 113.

5. BOARD CONFIGURATION

The jumperless FP-GPIO96 FeaturePak module is configured by software. The board must first be initialized, then configured. These operations can be done either using Diamond's Universal Driver (version 7.0 or higher) or by an independent set of equivalent register operations.

5.1 Configuring Using Universal Driver

Diamond Systems provides a device driver which will enable access to the board functionalities via an easy to use API set. This driver is called the Universal Driver and is available in Windows XP and Linux 2.6.xx operating systems. The details on the Universal driver can be found in the Universal Driver manual and can be accessed online at http://docs.diamondsystems.com/dscud/manual_Main+Page.html. The Universal Driver software comes on the Diamond Resource CD shipped with this product, or may be downloaded from the FP-GPIO96 webpage at www.diamondsystems.com/products/fpgpio96.

5.2 Configuring Using Register Operations

The board can also be controlled using simple register read/write commands if you are willing to write your own driver. In typical modern operating systems, the user level applications cannot directly access the low level system information and don't have register level access. In order to communicate with any PCI device, a device driver is required.

The Universal Driver mentioned above can be also be used to do register-level control, and a programmer could develop his own driver functionality that uses simple register read/write command after performing a PCI scan using the Universal Driver. Users of this type of access need to understand the board register map which is defined in later sections of this manual. This type of approach is suitable for someone who is very aware of the nature of low-level operations of hardware.

5.2.1 Interrupt level

Interrupts are used for hardware I/O operations that are independent of normal program flow. The FP-GPIO96 can be set up to generate interrupts under several circumstances. The board can generate interrupts to transfer digital data into the board, as well as at regular intervals according to a programmable timer on the board. Individual control bits are used to enable each type of interrupt.

Since the FP-GPIO96 board works on PCI Express bus architecture, the interrupt level is obtained as a result of a PCI scan performed by the device driver. To obtain the interrupt level used by the board, DSC provides a default device driver which can perform low level PCI commands and provide user level access to the board. The driver is from a third-party driver developer and is called WinDriver.

If you do not wish to use this driver and would like to develop your own driver, you need to be knowledgeable on the PCI / PCI express system architecture as well as the device driver model and architecture details for your chosen operating system.

6. I/O REGISTERS

The FP-GPIO96 register map consists of 256 bytes, divided into 16 16-byte blocks in the system I/O address space. Direct register access is not required if you are using Diamond's Universal Driver software that ships with the board. The driver handles all board access and provides a high-level set of functions to simplify programming. The information presented here and in the next chapter is intended to provide a detailed description of the board's features and operation, as well as for programmers who are not using the Universal Driver software.

6.1 I/O Map Summary

Block (Dec)	Range (Dec)	Range (Hex)	Function
0	0-15	0-F	
1	16-31	10-1F	
2	32-47	20-2F	DIO group A
3	48-63	30-3F	Counters, PWM
4	64-79	40-4F	
5	80-95	50-5F	
6	96-111	60-6F	DIO group B
7	112-127	70-7F	Interrupts, Misc., and ID
8	128-143	80-8F	
9	144-159	90-9F	
10	160-175	A0-AF	
11	176-191	B0-BF	
12	192-207	C0-CF	
13	208-223	D0-DF	
14	224-239	E0-EF	SPI Flash Interface
15	240-255	F0-FF	

The FP-GPIO96 board is a PCI Express based design and has 255 bytes of addressable registers as shown in the table above. Since in PCI architecture, the I/O base address is obtained as a result of a PCI scan on the Vendor ID and Device ID of the PCI device, the base address is not shown in the table; instead, offsets from the base address BAR0 are shown for individual functional blocks.

The FP-GPIO96 Vendor ID is 0x1C0E and the Device ID is 0x0900. When a PCI scan is performed using these two IDs, the board is detected and the register BAR0 gets the base address for the start of where registers are mapped. For the user application, the address information of BAR0 serves as the base address of the board and the rest of the registers are all accessed as an offset from the BAR0 address.

In the following material, register block addresses are shown in a format as in this example:

BAR0 + 32 (0x20) Read/Write/Command A/D Block Registers

Where the address is given as BAR0 + offset amount, with the number in decimal and the hex equivalent in parentheses. This is followed by the register block group name.

Registers are Read, Read/Write, Write, or Command, where Command registers can be written but cannot be read from.

6.2 I/O Register Details

This section describes the location and general behavior of specific bits in each I/O map register. In all register definitions below, any bit without a name is not defined and serves no function.

GROUP A

Offset	7	6	5	4	3	2	1	0
0	DIOA7-0							
1	DIOB7-0							
2	DIOC7-0							
3	DIOD7-0							
4	DIOE7-0							
5	DIOF7-0							
6								
7								
8								DIRA
9								DIRB
10							DIRCH	DIRCL
11								DIRD
12	DIRE7-0							
13	DIRF7-0							
14								
15								

GROUP B

Offset	7	6	5	4	3	2	1	0
0	DIOG7-0							
1	DIOH7-0							
2	DIOJ7-0							
3	DIOK7-0							
4	DIOL7-0							
5	DIOM7-0							
6								
7								
8								DIRG
9								DIRH
10								DIRJ
11								DIRK
12								DIRL
13								DIRM
14								
15								

6.2.1 BAR0 + 32 (0x20) DIO Block A Registers

These registers provide control of digital I/O ports. To use the ports, they must first be configured using Mode and Dir fields, and then can be read from and written to.

BAR0 + 32 (0x20) Read/Write Digital I/O port A

Bit No.	7	6	5	4	3	2	1	0
Name	DIOA7-0							
Reset value	0	0	0	0	0	0	0	0

DIOA7-0 This register is used for digital I/O on byte addressable port A. When port A is in output mode, the output signal lines DIO A7-0 (see Section 3.3) will be set to the values in this register, and reading this register will read back the programmed value. When port A is in input mode, this register will read back the logic levels on signal lines DIO A7-0, and writing to this register will have no effect. The direction of port A is controlled by the bit DIRA in the DIO control register at BAR0+40.

The DIO port A defaults to input mode on power up and all the register bits reset to 0.

BAR0 + 33 (0x21) Read/Write Digital I/O port B

Bit No.	7	6	5	4	3	2	1	0
Name	DIOB7-0							
Reset value	0	0	0	0	0	0	0	0

DIOB7-0 This register is used for digital I/O on byte addressable port B. When port B is in output mode, the output signal lines DIO B7-0 (see Section 3.3) will be set to the values in this register, and reading this register will read back the programmed value. When port B is in input mode, this register will read back the logic levels on signal lines DIO B7-0, and writing to this register will have no effect. The direction of port B is controlled by bit DIRB in the DIO control register at BAR0+41.

The DIO port B defaults to input mode on power up and all the register bits reset to 0.

BAR0 + 34 (0x22) Read/Write Digital I/O port C

Bit No.	7	6	5	4	3	2	1	0
Name	DIOC7-0							
Reset value	0	0	0	0	0	0	0	0

DIOC7-0 This register is used for digital I/O on byte addressable port C. When port C is in output mode, the output signal lines DIO C7-0 (see Section 3.3) will be set to the values in this register, and reading this register will read back the programmed value. When port C is in input mode, this register will read back the logic levels on signal lines DIO C7-0, and writing to this register will have no effect. The direction of port C is controlled by bit DIRCH and DIRCL in the DIO control register at BAR0+42.

The DIO port C defaults to input mode on power up and all the register bits reset to 0.

BAR0 + 35 (0x23) Read/Write Digital I/O port D

Bit No.	7	6	5	4	3	2	1	0
Name	DIOD7-0							
Reset value	0	0	0	0	0	0	0	0

DIOD7-0 This register is used for digital I/O on byte addressable port D. When port D is in output mode, the output signal lines DIO D7-0 (see Section 3.3) will be set to the values in this register, and reading this register will read back the programmed value. When port D is in input mode, this register will read back the logic levels on signal lines DIO D7-0, and writing to this register will have no effect. The direction of port D is controlled by bit DIRD in the DIO control register at BAR0+43. The DIO port D defaults to input mode on power up and all the register bits reset to 0.

BAR0 + 36 (0x24) Read/Write Digital I/O port E

Bit No.	7	6	5	4	3	2	1	0
Name	DIOE7-0							
Reset value	0	0	0	0	0	0	0	0

DIOE7-0 This register is used for digital I/O on bit addressable port E. When port E is in output mode, the output signal lines DIO E7-0 on (see Section 3.3) will be set to the values in this register, and reading this register will read back the programmed value. When port E is in input mode, this register will read back the logic levels on signal lines DIO E7-0, and writing to this register will have no effect. The direction of port E is controlled by DIRE7-0 bits in the register at BAR0+44. Each bit in the direction register controls the direction of the corresponding port bit.

The DIO port E defaults to input mode on power up and all the register bits reset to 0.

BAR0 + 37 (0x25) Read/Write Digital I/O port F

Bit No.	7	6	5	4	3	2	1	0
Name	DIOF7-0							
Reset value	0	0	0	0	0	0	0	0

DIOF7-0 This register is used for digital I/O on bit addressable port F. When port F is in output mode, the output signal lines DIO F7-0 (see Section 3.3) will be set to the values in this register, and reading this register will read back the programmed value. When port F is in input mode, this register will read back the logic levels on signal lines DIO F7-0, and writing to this register will have no effect. The direction of port F is controlled by DIRF7-0 bits in the register at BAR0+45. Each bit in the direction register controls the direction of the corresponding port bit.

The DIO port F defaults to input mode on power up and all the register bits reset to 0.

BAR0 + 38 (0x26) Write DIO Port A Configuration

Bit No.	7	6	5	4	3	2	1	0
Name								DIRA
Reset value								0

This register is used to configure the direction and mode control of the DIO port A. The DIO port A can be configured in either input or output direction.

DIRA Direction control bit for DIO port A.
 1 = DIO Port A is configured as an output port.
 0 = DIO Port A is configured as an input port. (Default setting)

BAR0 + 38 (0x26) Read DIO Port A Configuration

Bit No.	7	6	5	4	3	2	1	0
Name								DIRA
Reset value								0

This register provides a read back of the configuration of DIO port A.

DIRA Read back of the direction setting of DIO port A.
 1 = DIO port A is configured as an output.
 0 = DIO port A is configured as an input. (Default setting)

BAR0 + 39 (0x27) Write DIO Port B Configuration

Bit No.	7	6	5	4	3	2	1	0
Name								DIRB
Reset value								0

This register is used to configure the direction and mode control of the DIO port B. The DIO port B can be configured in either input or output direction.

DIRB Read back of the direction setting of DIO port B.
 1 = DIO port B is configured as an output.
 0 = DIO Port B is configured as an input port. (Default setting)

BAR0 + 39 (0x28) Read DIO Port B Configuration

Bit No.	7	6	5	4	3	2	1	0
Name								DIRB
Reset value								

This register provides a read back of the configuration of DIO port B.

DIRB Read back of the direction setting of DIO port B.
 1 = DIO port B is configured as an output.
 0 = DIO port B is configured as an input. (Default setting)

BAR0 + 40 (0x29) Write DIO Port C Configuration

Bit No.	7	6	5	4	3	2	1	0
Name							DIRCH	DIRCL
Reset value							0	0

This register is used to configure the direction and mode control of the DIO port C. Each half of the DIO port C can be configured in either input or output direction.

DIRCH Direction control bit for DIO port C upper 4 bits.
 1 = DIO Port C7-4 is configured as an output port.
 0 = DIO Port C7-4 is configured as an input port. (Default setting)

DIRCL Direction control bit for DIO port C lower 4 bits.
 1 = DIO Port C3-0 is configured as an output port.
 0 = DIO Port C3-0 is configured as an input port. (Default setting)

BAR0 + 40 (0x29) Read DIO Port C Configuration

Bit No.	7	6	5	4	3	2	1	0
Name							DIRCH	DIRCL
Reset value							0	0

This register provides a read back of the configuration of DIO port C.

DIRCH Direction control bit for DIO port C upper 4 bits.
 1 = DIO Port C7-4 is configured as an output port.
 0 = DIO Port C7-4 is configured as an input port. (Default setting)

DIRCL Direction control bit for DIO port C lower 4 bits.
 1 = DIO Port C3-0 is configured as an output port.
 0 = DIO Port C3-0 is configured as an input port. (Default setting)

BAR0 + 41 (0x2A) Write DIO Port D Configuration

Bit No.	7	6	5	4	3	2	1	0
Name								DIRD
Reset value								0

This register is used to configure the direction and mode control of the DIO port D. The DIO port D can be configured in either input or output direction.

DIRD Direction control bit for DIO port D.
 1 = DIO Port D is configured as an output port.
 0 = DIO Port D is configured as an input port. (Default setting)

BAR0 + 41 (0x2A) Read DIO Port D Configuration

Bit No.	7	6	5	4	3	2	1	0
Name								DIRD
Reset value								0

This register provides a read back of the configuration of DIO port D.

DIRD Read back of the direction setting of DIO port D.
 1 = DIO port D is configured as an output.
 0 = DIO port D is configured as an input. (Default setting)

BAR0 + 42 (0x2C) Read/Write DIO Port E Configuration

Bit No.	7	6	5	4	3	2	1	0
Name	DIRE7-0							
Reset value	0	0	0	0	0	0	0	0

This register controls the direction for DIO port E. Each of the DIO port E bits is controllable individually using corresponding bit in this register as either input or output.

DIRE7-0 These bits provide direction configuration of the DIO port E. When any bit is 0, the corresponding DIO port E bit is configured as an input while the port bit acts as an output when the corresponding bit in this register is set to 1.

The default value of this register is 0 which means that all bits of DIO port E are configured as inputs. Below are a few examples of various configurations.

DIRE7-0 = 0x0F - Port E bits 7, 6, 5 and 4 are input while bits 3, 2, 1 and 0 are output.
DIRE7-0 = 0xC0 - Port E bits 7 and 6 are output and all other bits are inputs.

BAR0 + 43 (0x2D) Read/Write DIO Port F Configuration

Bit No.	7	6	5	4	3	2	1	0
Name	DIRF7-0							
Reset value	0	0	0	0	0	0	0	0

This register controls the direction for DIO port F. Each of the DIO port F bits is controllable individually using corresponding bit in this register as either input or output.

DIRF7-0 These bits provide direction configuration of the DIO port F. When any bit is 0, the corresponding DIO port F bit is configured as an input while the port bit acts as an output when the corresponding bit in this register is set to 1.

The default value of this register is 0 which means that all bits of DIO port F are configured as inputs.

6.2.2 BAR0 + 32 (0x20) DIO Block B Registers

These registers provide control of digital I/O ports. To use the ports, they must first be configured using Mode and Dir fields, and then can be read from and written to.

BAR0 + 96 (0x60) Read/Write Digital I/O port G

Bit No.	7	6	5	4	3	2	1	0
Name	DIOG7-0							
Reset value	0	0	0	0	0	0	0	0

DIOG7-0 This register is used for digital I/O on byte addressable port G. When port G is in output mode, the output signal lines DIO G7-0 (see Section 3.3) will be set to the values in this register, and reading this register will read back the programmed value. When port G is in input mode, this register will read back the logic levels on signal lines DIO G7-0, and writing to this register will have no effect. The direction of port G is controlled by the bit DIRG in the DIO control register at BAR0+104.

The DIO port G defaults to input mode on power up and all the register bits reset to 0.

BAR0 + 97 (0x61) Read/Write Digital I/O port H

Bit No.	7	6	5	4	3	2	1	0
Name	DIOH7-0							
Reset value	0	0	0	0	0	0	0	0

DIOH7-0 This register is used for digital I/O on byte addressable port H. When port H is in output mode, the output signal lines DIO H7-0 (see Section 3.3) will be set to the values in this register, and reading this register will read back the programmed value. When port H is in input mode, this register will read back the logic levels on signal lines DIO H7-0, and writing to this register will have no effect. The direction of port H is controlled by bit DIRH in the DIO control register at BAR0+109.

The DIO port H defaults to input mode on power up and all the register bits reset to 0.

BAR0 + 98 (0x62) Read/Write Digital I/O port J

Bit No.	7	6	5	4	3	2	1	0
Name	DIOJ7-0							
Reset value	0	0	0	0	0	0	0	0

DIOJ7-0 This register is used for digital I/O on byte addressable port J. When port J is in output mode, the output signal lines DIO J7-0 (see Sec 3.3) are set to the register's values, and reading this register reads back the programmed value. When port J is in input mode, this register reads back the logic levels on signal lines DIO J7-0, writing to this register does nothing. The direction of port C is controlled by bit DIRJ in the DIO control register at BAR0+110.

The DIO port J defaults to input mode on power up and all the register bits reset to 0.

BAR0 + 99 (0x63) Read/Write Digital I/O port K

Bit No.	7	6	5	4	3	2	1	0
Name	DIOK7-0							
Reset value	0	0	0	0	0	0	0	0

DIOK7-0 This register is used for digital I/O on byte addressable port K. When port K is in output mode, the output signal lines DIO K7-0 (see Section 3.3) will be set to the values in this register, and reading this register will read back the programmed value. When port K is in input mode, this register will read back the logic levels on signal lines DIO K7-0, and writing to this register will have no effect. The direction of port D is controlled by bit DIRK in the DIO control register at BAR0+111.

The DIO port K defaults to input mode on power up and all the register bits reset to 0.

BAR0 + 100 (0x64) Read/Write Digital I/O port L

Bit No.	7	6	5	4	3	2	1	0
Name	DIOL7-0							
Reset value	0	0	0	0	0	0	0	0

DIOL7-0 This register is used for digital I/O on bit addressable port L. When port L is in output mode, the output signal lines DIO L7-0 on (see Section 3.3) will be set to the values in this register, and reading this register will read back the programmed value. When port L is in input mode, this register will read back the logic levels on signal lines DIO L7-0, and writing to this register will have no effect. The direction of port L is controlled by DIDL7-0 bits in the register at BAR0+112. Each bit in the direction register controls the direction of the corresponding port bit. The DIO port L defaults to input mode on power up and all the register bits reset to 0.

BAR0 + 101 (0x65) Read/Write Digital I/O port M

Bit No.	7	6	5	4	3	2	1	0
Name	DIOM7-0							
Reset value	0	0	0	0	0	0	0	0

DIRM Direction control bit for DIO port M.
 1 = DIO Port M is configured as an output port.
 0 = DIO Port M is configured as an input port. (Default setting)

The DIO port M defaults to input mode on power up and all the register bits reset to 0.

BAR0 + 104 (0x68) Write DIO Port G Configuration

Bit No.	7	6	5	4	3	2	1	0
Name								DIRG
Reset value								0

This register is used to configure the direction and mode control of the DIO port A. The DIO port A can be configured in either input or output direction.

DIRG Direction control bit for DIO port G.
 1 = DIO Port G is configured as an output port.
 0 = DIO Port G is configured as an input port. (Default setting)

BAR0 + 104 (0x68) Read DIO Port G Configuration

Bit No.	7	6	5	4	3	2	1	0
Name								DIRG
Reset value								0

This register provides a read back of the configuration of DIO port G.

DIRG Read back of the direction setting of DIO port G.
 1 = DIO port A is configured as an output.
 0 = DIO port A is configured as an input. (Default setting)

BAR0 + 105 (0x69) Write DIO Port H Configuration

Bit No.	7	6	5	4	3	2	1	0
Name								DIRH
Reset value								0

This register is used to configure the direction and mode control of the DIO port H. The DIO port H can be configured in either input or output direction.

DIRH Read back of the direction setting of DIO port H.
 1 = DIO port H is configured as an output.
 0 = DIO Port H is configured as an input port. (Default setting)

BAR0 + 105 (0x70) Read DIO Port H Configuration

Bit No.	7	6	5	4	3	2	1	0
Name								DIRH
Reset value								0

This register provides a read back of the configuration of DIO port H.

DIRH Read back of the direction setting of DIO port H.
 1 = DIO port B is configured as an output.
 0 = DIO port B is configured as an input. (Default setting)

6.2.3 BAR0 + 48 (0x30) Counters, PWM Block Registers

Offset	7	6	5	4	3	2	1	0
0	CTRD7-0							
1	CTRD15-8							
2	CTRD23-16							
3	CTRD31-24							
4 (W)	CTRN7-0							
5 (C)	CTRCMD3	CTRCMD2	CTRCMD1	CTRCMD0			CCD1	CCD0
6								
7							CTRIO1	CTRIO0
8	PWMD7-0							
9	PWMD15-8							
10	PWMD23-16							
11 (W)	PWCMD3	PWCMD2	PWCMD1	PWCMD0	PWMC	PWM2	PWM1	PWM0
12 (W)								
13 (W)								
14 (C)								
14 (R)								
15								

The FP-GPIO96 contains 8 32-bit up/down counter timers with programmable functions. The counters are programmed using a command register at address 5 in the counter block, a counter number register at address 4, and a 32-bit data register CTRD31-0 at addresses 0-3.

Offset	7	6	5	4	3	2	1	0
5 (C)	CTRCMD3	CTRCMD2	CTRCMD1	CTRCMD0			CCD1	CCD0

CTRCMD3-0 selects the command to execute on the counter specified in register 4. CCD1-0 is additional data to be used in combination with certain commands.

0000 = Clear the selected counter.

0001 = Load the selected counter with data in registers 0-3. This is used for down counting operations only.

0010 = Select count direction. CCD0=1 means count up, and CCD0=0 means count down.

0011 = Enable / disable external gate. CCD0 = 1 means enable gating, CCD0=0 means disable gating. This function is valid for counter 1 only. When this command is selected for counter 1, DIO pin P_AUX5 is reconfigured as an input and used for counter 1 gate.

0100 = Enable / disable counting. CCD0 = 1 means enable counting, CCD0=0 means disable counting.

0101 = Latch selected counter. A counter must be latched before its contents can be read. Latching can occur while the counter is counting. The latched data is available in CTRD31-0.

0110 = Select counter clock source and frequency according to CCD1-0:

CCD1	CCD0	Function
0	X	Counter input pin (see next page), active low
1	0	Internal clock 50MHz
1	1	Internal clock 5MHz

1111 = Reset the counter. If CCD0 = 0, then only the counter specified in register 4 is reset. If CCD0 = 1 then all counters are reset, disabling all counters and clearing all registers to zero. Thus a command of 0xFF will reset all counters.

The counters are enabled on digital I/O lines using the CTRIO0 and CTRIO1 bits in the register located at offset 7. A 1 for the associated counter enable bit enables four of the counter I/O signals on the specified digital I/O lines and forces those lines to the directions specified in the table. A 0 disables four of the counter I/O signals and maintains the I/O lines as standard digital I/O lines. The counter timer inputs and outputs are assigned to pins of ports A, B and C according to the following tables:

Function	Digital I/O pin	Direction when CTRIO0 = 1
Counter 0 In	P_DIOA0	Input
Counter 0 Gate	P_DIOA1	Input
Counter 0 Output	P_DIOC0	Output
Counter 1 In	P_DIOA2	Input
Counter 1 Gate	P_DIOA3	Input
Counter 1 Output	P_DIOC1	Output
Counter 2 In	P_DIOA4	Input
Counter 2 Gate	P_DIOA5	Input
Counter 2 Output	P_DIOC2	Output
Counter 3 In	P_DIOA6	Input
Counter 3 Gate	P_DIOA7	Input
Counter 3 Output	P_DIOC3	Output

Function	Digital I/O pin	Direction when CTRIO1 = 1
Counter 4 In	P_DIOB0	Input
Counter 4 Gate	P_DIOB1	Input
Counter 4 Output	P_DIOC4	Output
Counter 5 In	P_DIOB2	Input
Counter 5 Gate	P_DIOB3	Input
Counter 5 Output	P_DIOC5	Output
Counter 6 In	P_DIOB4	Input
Counter 6 Gate	P_DIOB5	Input
Counter 6 Output	P_DIOC6	Output
Counter 7 In	P_DIOB6	Input
Counter 7 Gate	P_DIOB7	Input
Counter 7 Output	P_DIOC7	Output

If the counter I/O signals are disabled, the counter may still operate using an internal clock source and no gating; however external clock and gate functions will not function.

Each counter's output operates as follows. When disabled or during normal counting operation, the output is 0. When count direction is up, the output is always 0. When count direction is down, then when the counter reaches 0, the output will go high, and the counter will immediately reload to its initial value. Thus a counter value of n will result in a divide by n output pulse rate. If a counter latch command is requested during this process, the command will be delayed until the reload is completed.

BAR0 +48 (0x30) Read/Write Counter Byte 0 (LSB)

Bit No.	7	6	5	4	3	2	1	0
Name	CTRD7-0							
Reset value	0	0	0	0	0	0	0	0

This register is used for all counters. The selected counter holds the LSB of the counter data for the counter indicated by the counter number register.

When writing to this register, the value is written to an internal register first and when a command is issued at the Counter command register at BAR0+53, the value is actually reflected in the selected counter.

When reading from this register, the value returned by the register is the value that was latched on the last latch command issued to the counter. Thus the value returned is not the value written to the counter.

BAR0 + 49 (0x01) Read/Write Counter Byte 1

Bit No.	7	6	5	4	3	2	1	0
Name	CTRD15-8							
Reset value								

This register is used for all counters. The counter holds byte 1 of the counter data for either counter indicated by the counter number register.

When writing to this register, the value is written to an internal register first and when a command is issued at the Counter command register at BAR0+53, the value is actually reflected in the selected counter.

When reading from this register, the value returned by the register is the value that was latched on the last latch command issued to the counter. Thus the value returned is not the value written to the counter.

BAR0 + 50 (0x02) Read/Write Counter Byte 2

Bit No.	7	6	5	4	3	2	1	0
Name	CTRD23-16							
Reset value								

This register is used for all counters. The counter holds byte 2 of the counter data for either counter indicated by the counter number register.

When writing to this register, the value is written to an internal register first and when a command is issued at the Counter command register at BAR0+53, the value is actually reflected in the selected counter.

When reading from this register, the value returned by the register is the value that was latched on the last latch command issued to the counter. Thus the value returned is not the value written to the counter.

BAR0 + 51 (0x03) Read/Write Counter Byte 3(MSB)

Bit No.	7	6	5	4	3	2	1	0
Name	CTRD31-24							
Reset value								

This register is used for all counters. The counter holds byte 3 (<MSB) of the counter data for either counter indicated by the counter number register.

When writing to this register, the value is written to an internal register first and when a command is issued at the Counter command register at BAR0+53, the value is actually reflected in the selected counter.

When reading from this register, the value returned by the register is the value that was latched on the last latch command issued to the counter. Thus the value returned is not the value written to the counter.

BAR0 + 52 (0x34) Write Counter Number Register

Bit No.	7	6	5	4	3	2	1	0
Name	CTRN7-0							
Reset value	0	0	0	0	0	0	0	0

CTRN7-0 Counter number register. Values of 0 through 7 are valid values for this register.

BAR0 + 53 (0x35) Write Counter Command Register

Bit No.	7	6	5	4	3	2	1	0
Name	CTRCMD3-0				X	X	CCD1	CCD0
Reset value	0	0	0	0			0	0

This register has various commands to control the behavior of the counter selected by the value in the Counter Number register.

CTRCMD3-0 These bits provide the following control commands for the counter/timer: clear, load, enable, disable, reset, latch and select counter clock source.

CCD1-0 These bits are additional control bits and operate with the CTRCMD3-0 bits to provide additional ability to control the counter behavior. Their use is explained in the following table.

CTRCMD3-0				Command	Control Bits		Action	Register Value
3	2	1	0		CCD 1	CCD 0		
0	0	0	0	Clear Counter.	X	X	-	0x00
0	0	0	1	Load the selected counter with data in CTRD32-0.	X	X	-	0x10
0	0	1	0	Select Count Direction.	X	1	Count up	0x21
					X	0	Count down	0x20
0	0	1	1	Enable / Disable External counter gate.	X	1	Enable Gating	0x31
					X	0	Disable Gating	0x30
0	1	0	0	Enable/Disable counting.	X	1	Enable Counting	0x41
					X	0	Disable Counting	0x40
0	1	0	1	Latch Selected counter.	X	X	-	0x50
0	1	1	0	Select Counter clock source.	0	X	Counter Input pin	0x60
					1	0	Internal CLK 40MHz	0x62
					1	1	Internal CLK 4MHz	0x63
1	1	1	1	Reset the counters.	X	0	Reset selected counter	0xF0
					X	1	Reset both counters	0xF1

BAR0 + 55 (0x37) Write Counter I/O Register

Bit No.	7	6	5	4	3	2	1	0
Name							CTRIO1	CTRIO0
Reset value							0	0

CTRIO1-0 These bits determine the function of the DIO ports A, B and C between digital IO or counter timer IO. CTRIO0 controls the selection between DIO port A with DIO port CL and counter timers 0 – 3. CTRIO1 controls the selection between DIO port B with DIO port CH and counter timers 4 – 7. When either bit is 0 the DIO ports are active and the counter timer signals are disabled. When either bit is 1 the DIO ports are disabled and the counter timer signals are active.

BAR0 + 56 (0x38) Read/Write PWM Data Register 0 (LSB)

Bit No.	7	6	5	4	3	2	1	0
Name	PWMD7-0							
Reset value	0	0	0	0	0	0	0	0

PWMD7-0 This register holds the LSB of the 24 bit PWM data value.

BAR0 + 57 (0x39) Read/Write PWM Data Register 1

Bit No.	7	6	5	4	3	2	1	0
Name	PWMD15-8							
Reset value	0	0	0	0	0	0	0	0

PWMD15-8 This register holds the second byte of the PWM data value.

BAR0 + 58 (0x3A) Read/Write PWM Data Register 2 (MSB)

Bit No.	7	6	5	4	3	2	1	0
Name	PWMD23-16							
Reset value								

PWMD23-16 This register holds the MSB of the 23 bit PWM data value.

BAR0 + 59 (0x3B) Write PWM Control Register

Bit No.	7	6	5	4	3	2	1	0
Name	PWCMD3-0				PWMCD	PWM2-0		
Reset value	0	0	0	0	0	0	0	0

This register provides PWM command information for various PWM operations. The different combinations of the register bits invoke the PWM command as shown in the table below.

PWCMD3-0 These bits contain the PWM command to execute on the PWM block.

The details of commands are as below.

- 0000 Stop all / selected PWM as indicated by PWMCD
0 = stop all PWMs (opposite polarity for "all" compared to other commands)
1 = stop PWM selected with PWM2-0
Command 0x00 = stop all PWMs
- 0001 Load counter C0 or C1 selected by PWMCD:
0 = load C0 / period counter
1 = load C1 = duty cycle counter
- 0010 Set polarity for output according to PWMCD. The pulse occurs at the start of the period.
0 = pulse high
1 = pulse low
- 0011 Enable/disable pulse output as indicated by PWMCD
0 = disable pulse output; output = opposite of polarity setting from command 0010
1 = enable pulse output
- 0100 Clear all / selected PWM as indicated by PWMCD
0 = clear PWM selected with PWM2-0
1 = clear all PWMs
- 0101 Enable/disable PWM outputs on DIO port F according to PWMCD
0 = disable output
1 = enable output on DIOFn where n = PWM number; this forces DIOFn to output mode
- 0110 Select clock source for PWM indicated by PWM2-0 according to PWMCD (both counters C0 and C1 use the same clock source):
0 = 50MHz
1 = 5MHz
- 0111 Start all / selected PWM as indicated by PWMCD
0 = start PWM selected with PWM2-0
1 = start all PWMs
Command 0x7F = start all PWMs

- PWMCMD** Additional control bit that performs a selection on the command indicated by PWMCMD3-0. The functionality of this bit is described above with PWMCMD3-0 bits.
- PWM2-0** PWM circuit number. The command indicated by PWMCMD3-0 is applied to the PWM circuit indicated by these bits.

6.2.4 BAR0 + 112 (0x70) Interrupts, Miscellaneous, and ID Block Registers

Offset from Block Base (Dec)	Bit 7	Bit 6	Bit 5	Bit 4	Bit 3	Bit 2	Bit 2	Bit 0
0			T3INTEN	T2INTEN	T1INTEN	T0INTEN	DINTEN	
1 (C)			T3INTCLR	T2INTCLR	T1INTCLR	T0INTCLR	DINTCLR	
1 (R)			T3INT	T2INT	T1INT	T0INT	DINT	
2								
3								
4								LED
5 (R)						SLOT2-0		
6						CFG1-0		
7								
8 (R)	FPGA ID minor							
8 (R)	FPGA ID major							
10 (R)	FPGA revision minor							
11 (R)	FPGA revision major							
12 (R)	Board ID minor							
13 (R)	Board ID major							
14 (R)	Board revision minor							
15 (C)	BRDRST	FPGARST						
15 (R)	Board revision major							

BAR0 + 112 (0x70) Read/Write Interrupt Enable Register

Bit No.	7	6	5	4	3	2	1	0
Name			T3INTEN	T2INTEN	T1INTEN	T0INTEN	DINTEN	
Reset value			0	0	0	0	0	

This register provides interrupt enable bits for various interrupts that the FP-GPIO96 board can generate. The on-board FPGA will not generate an interrupt unless the corresponding enable bit in this register is set to 1.

T3INTEN Timer 3 interrupt enable.
 1 = Timer 1 Interrupt is enabled. When the counter 1 reaches zero, the interrupt will be generated.
 0 = Timer 1 interrupt disabled. (Default setting)

T2INTEN Timer 2 interrupt enable.
 1 = Timer 1 Interrupt is enabled. When the counter 1 reaches zero, the interrupt will be generated.
 0 = Timer 1 interrupt disabled. (Default setting)

- T1INTEN** Timer 1 interrupt enable.
 1 = Timer 1 Interrupt is enabled. When the counter 1 reaches zero, the interrupt will be generated.
 0 = Timer 1 interrupt disabled. (Default setting)
- T0INTEN** Timer 0 interrupt enable.
 1 = Timer 0 Interrupt is enabled. When the counter 0 reaches zero, the interrupt will be generated.
 0 = Timer 0 interrupt disabled. (Default setting)
- DINTEN** DIO interrupt enable.
 1 = DIO Interrupt is enabled. The FPGA will generate an interrupt when any of the DIO ports is in Mode1 of operation. When DINTEN=1, DIOF6-7 are reassigned as follows: DIOF6 is a latch signal with input direction and default value high. DIOF7 is an acknowledge signal with output direction and default value high.
 0 = DIO interrupt is disabled.

BAR0 + 113 (0x71) Command (Write) Interrupt Flip-Flop Reset Register

Bit No.	7	6	5	4	3	2	1	0
Name			T3INTCLR	T2INTCLR	T1INTCLR	T0INTCLR	DINTCLR	
Reset value			0	0	0	0	0	

This register provides different command bits for resetting various interrupt flip-flop bits. For every interrupt type, a clear bit is provided which is required to be set to 1 by the interrupt service routine after every execution. If the corresponding clear bit is not set in the ISR, the FPGA will not generate any more interrupts.

This register accepts only one command at a time.

- T3INTCLR** Timer 3 interrupt request flip-flop reset bit.
 1 = Causes the timer 3 interrupt request flip-flop to be reset.
 0 = NO ACTION.
- T2INTCLR** Timer 2 interrupt request flip-flop reset bit.
 1 = Causes the timer 2 interrupt request flip-flop to be reset.
 0 = NO ACTION.
- T1INTCLR** Timer 1 interrupt request flip-flop reset bit.
 1 = Causes the timer 1 interrupt request flip-flop to be reset.
 0 = NO ACTION.
- T0INTCLR** Timer 0 interrupt request flip-flop reset bit.
 1 = Causes the timer 0 interrupt request flip-flop to be reset.
 0 = NO ACTION.
- DINTCLR** DIO interrupt request flip-flop reset bit,
 1 = Causes the DIO interrupt request flip-flop to be reset.
 0 = NO ACTION.

BAR0 + 114 (0x71) Read Interrupt Status Register

Bit No.	7	6	5	4	3	2	1	0
Name	X	X	X	X	T1INT	T0INT	DINT	
Reset value					0	0	0	0

This register provides status information on the interrupts generated by the FPGA. The user program can monitor the respective bits in this register to obtain the status on the interrupt that was configured.

T1INT Timer 1 interrupt status.
 1 = Timer 1 interrupt is pending.
 0 = Timer 1 interrupt is not pending.

T0INT Timer 0 interrupt status.
 1 = Timer 0 interrupt is pending.
 0 = Timer 0 interrupt is not pending.

DINT DIO interrupt status
 1 = DIO interrupt is pending.
 0 = DIO interrupt is not pending.

BAR0 + 118 (0x76) Read/Write Board Configuration Settings

Bit No.	7	6	5	4	3	2	1	0
Name	X	X	X	X	X	X	CFG1-0	
Reset value							0	0

CFG1-0 These bits provide information on the NVRAM on the board which holds the board configuration data. These bits provide the pull up-down configuration of both Group A and Group B DIO lines as shown in the table below.

CFG1	CFG0	DIO GROUPA Pull up-down	DIO GROUPB Pull up-down
0	0	PULL DOWN	PULL DOWN
0	1	PULL UP	PULL DOWN
1	0	PULL DOWN	PULL UP
1	1	PULL UP	PULL UP

The value written in these bits are stored on a non-volatile on-board memory. The board powers up to the status saved in these bits. A board reset will NOT result in these bits being reset to their factory defaults.

BAR0 + 119 (0x77) Read UNUSED
BAR0 + 120 (0x78) Read FPGA ID Minor Register

Bit No.	7	6	5	4	3	2	1	0
Name	FPGA ID minor							
Reset value	0	0	0	0	0	0	0	1

FPGA ID minor This register provides information on the FPGA ID. This register will read 0x00.

BAR0 + 121 (0x79) Read FPGA ID Major Register

Bit No.	7	6	5	4	3	2	1	0
Name	FPGA ID major							
Reset value	0	0	0	0	0	0	0	0

FPGA ID major This register will return the major ID number of the FPGA. At present it will read 0x09.

BAR0 + 122 (0x7A) Read FPGA Revision Register

Bit No.	7	6	5	4	3	2	1	0
Name	FPGA revision minor							
Reset value	0	0	0	0	0	0	0	0

FPGA revision minor Returns a value of 0x00.

BAR0 + 123 (0x7B) Read FPGA Revision Register

Bit No.	7	6	5	4	3	2	1	0
Name	FPGA revision major							
Reset value	0	0	0	0	0	0	0	0

FPGA revision major Returns a value of 0x01.

BAR0 + 124 (0x7C) Read Board ID Minor Register

Bit No.	7	6	5	4	3	2	1	0
Name	Board ID minor							
Reset value	0	0	0	0	0	0	0	1

FPGA ID minor This register holds the FPGA ID minor (LSB) for the product. Every DSC product has an FPGA ID. FP-GPIO96 has an FPGA ID of 0x0801.

This register always returns 0x01.

BAR0 + 125 (0x7D) Read Board ID Major Register

Bit No.	7	6	5	4	3	2	1	0
Name	Board ID major							
Reset value	0	0	0	0	1	0	0	0

FPGA ID major This register holds the FPGA ID major (MSB) for the product. This register always returns 0x08.

BAR0 + 126 (0x7E) Read FPGA Firmware Minor Revision Number

Bit No.	7	6	5	4	3	2	1	0
Name	FPGA revision minor							
Reset value	0	0	0	0	0	1	0	0

FPGA revision minor This register has the minor revision number for the FPGA firmware. Every time the FPGA firmware is updated, this register gets a new value.

This register will return a value of 0x04.

BAR0 + 127 (0x7F) Command (Write) Reset Register

Bit No.	7	6	5	4	3	2	1	0
Name	BRDRST	FPGARST						
Reset value	0							

This register provides a control bits to reset the entire board.

BRDRST Board Reset bit.

1 = Causes the entire board to be reset. This includes all the peripherals and the internal FPGA registers.

0 = NO ACTION.

FPGARST FPGA Reset bit.

1 = Causes the FPGA to be reset. This may be required when the FPGA logic image is updated and saved in its SPI flash IC.

0 = NO ACTION.

BAR0 + 127 (0x7F) Read Board Revision Major Number

Bit No.	7	6	5	4	3	2	1	0
Name	Board revision major							
Reset value	0	0	0	0	0	0	0	1

Board revision major This register has the major revision number of the board.

6.2.5 BAR0 + 224 (0xE0) SPI Flash Interface Block Registers

Offset from Block Base (Dec)	Bit 7	Bit 6	Bit 5	Bit 4	Bit 3	Bit 2	Bit 2	Bit 0
0	SPITXD7-0							
1	SPIRXD7-0							
2	SPICMD7-0							
3 (R)						SPIRXRDY	SPITXRDY	SPIBUSY
4	SPIA7-0							
5	SPIA15-8							
6	SPIA23-16							
7								
8								
9								
10								
11								
12								
13								
14								
15								

BAR0 + 224 (0xE0) Read/Write SPI Transmit Data Register

Bit No.	7	6	5	4	3	2	1	0
Name	SPITXD7-0							
Reset value	0	0	0	0	0	0	0	0

SPITXD7-0 This register holds the data to be written to the SPI flash memory on the board. The FP-GPIO96 board's firmware is held in this memory. If invalid data pattern is written to the device, the board will become unusable.

BAR0 + 225 (0xE1) Read/Write SPI Receive Data Register

Bit No.	7	6	5	4	3	2	1	0
Name	SPIRXD7-0							
Reset value	0	0	0	0	0	0	0	0

SPIRXD7-0 These bits provide the data read from the SPI flash device.

BAR0 + 226 (0xE2) Write SPI Command Register

Bit No.	7	6	5	4	3	2	1	0
Name	SPICMD7-0							
Reset value	0	0	0	0	0	0	0	0

SPICMD7-0 These bits indicate the type of command to send to the SPI flash device. The commands are as below.

The following SPI commands are available:

- 0x01 WRSR write status register
- 0x02 PP page program
- 0x03 RD read data
- 0x04 WRDI write disable
- 0x05 RDSR read status register
- 0x06 WREN write enable
- 0x0B FRD fast read data
- 0xAB RES read signature
- 0xC7 BE bulk erase
- 0xB9 DP deep power down
- 0xD8 SE sector erase
- 0xFF NOP no command to execute / end current command

BAR0 + 227 (0xE3) Read SPI Status Register

Bit No.	7	6	5	4	3	2	1	0
Name	X	X	X	X	X	SPIRXRDY	SPITXRDY	SPIBUSY
Reset value						0	0	0

This register provides status information on the SPI communication interface between the FPGA and the SPI flash device.

- SPIRXRDY** SPI flash ready to receive status bit.
 1 = When the SPI receive buffer has at least one byte available for reading (SPI RX FIFO not empty).
 0 = SPI receive buffer is empty.
- SPITXRDY** SPI flash ready to transmit status bit.
 1 = When the SPI transmit buffer has room for at least one byte of transmit data (SPI TX FIFO not full).
 0 = SPI transmit buffer is empty.
- SPIBUSY** SPI busy status bit. Application software must check this bit before performing any operation on the SPI bus.
 1 = SPI circuit is busy.
 0 = SPI circuit is IDLE.

BAR0 + 228 (0xE4) Read/Write SPI Address Register LSB

Bit No.	7	6	5	4	3	2	1	0
Name	SPIA7-0							
Reset value	0	0	0	0	0	0	0	0

SPIA7-0 This register holds the LSB of the 24 bit SPI address. The SPI address is required for every read/write operation.

BAR0 + 229 (0xE5) Read/Write SPI Address Register Byte 2

Bit No.	7	6	5	4	3	2	1	0
Name	SPIA15-8							
Reset value	0	0	0	0	0	0	0	0

SPIA15-8 This register holds the second byte of the 24 bit SPI address. The SPI address is required for every read/write operation.

BAR0 + 230 (0xE6) Read/Write SPI Address Register Byte 3

Bit No.	7	6	5	4	3	2	1	0
Name	SPIA23-16							
Reset value	0	0	0	0	0	0	0	0

SPIA23-16 This register holds the MSB of the 24 bit SPI address. The SPI address is required for every read/write operation.

7. DIGITAL I/O OPERATION

The FP-GPIO96 has twelve 8-bit bidirectional digital I/O ports, named A-M (excluding "I"). The DIO block is controlled and configured using registers at BAR0+32 to 67 as shown in the tables below.

GROUP A

Offset from BAR0	7	6	5	4	3	2	1	0
32	DIOA7-0							
33	DIOB7-0							
34	DIOC7-0							
35	DIOD7-0							
36	DIOE7-0							
37	DIOF7-0							
38								
39								
40								DIRA
41								DIRB
42							DIRCH	DIRCL
43								DIRD
44	DIRE7-0							
45	DIRF7-0							
46								
47								

GROUP B

Offset from BAR0	7	6	5	4	3	2	1	0
96	DIOG7-0							
97	DIOH7-0							
98	DIOJ7-0							
99	DIOK7-0							
100	DIOL7-0							
101	DIOM7-0							
102								
103								
104								DIRG
105								DIRH
106								DIRJ
107								DIRK
108								DIRL
109								DIRM
110								
111								

DIOx7-0	DIO port n data where x = A-H, J-M
DIR[A-D], DIR[G,H,J-M]	Direction control bits for DIO ports A-D 0 = Port is Input 1 = Port is an Output
DIRE7-0	Direction control bits for DIO port E 0 = Respective bit is input 1 = Bit is output
DIRF7-0	Direction control bits for DIO port F 0 = Respective bit is input 1 = Bit is output

Ports A-D are 8-bit ports with direction programmable byte by byte. Register bits DIRA-D control the direction of these ports and also the direction of the port pins where a value of 0 = input and 1 = output. In output mode, the values in these registers drive their associated I/O pins. The logic levels on the I/O pins may be read back in both input and output modes. These ports reset to 0 and input mode during power-up, reset, FPGARST=1, or BRDRST=1. If a port is in input mode, its output register may still be written to. When the port is switched to output mode, the value of the output register will drive the corresponding I/O pins.

Ports E-F are 8-bit ports with direction programmable bit by bit according to register bits DIRE7-0 and DIRF7-0 where a value of 0 = input, 1 = output. I/O pins DIOF3-0 may be reassigned as PWM outputs; see the PWM circuit description.

7.1 Digital I/O Configuration Register

The direction control register is programmed by writing to the registers at offset 40-45. Once you have set the port directions with this register, you can read and write to the ports as desired. These registers allow you to set the direction as well as the mode of operation for the respective ports.

Below are several examples on how to configure various DIO ports.

To configure DIO port A as output port:

```
outp ( base + 40 , 0x01 ) ;// DIRA=1 (bit 0)
```

To configure DIO port D as input port:

```
outp ( base + 43 , 0x00 ) ;// DIRD=0 (bit 0)
```

To configure DIO port F bits 4-7 as input and bits 0-3 as output

```
outp ( base + 45, 0x0F);
```

7.2 Outputting data to a DIO port

To output data on a DIO port, the DIO data register corresponding to the port being used should be written with the value that needs to be output.

For example, to output 0x55 on DIO port A:

```
outp ( base + 40 , 0x01 ) ;// SET DIO PORT A DIRECTION AS OUTPUT ( DIRA = 1 )  
outp ( base + 32 , 0x55 ) ;// WRITE THE DATA REGISTER TO SEND THE DATA OUT.
```

7.3 Reading data from a DIO port

To read data from a DIO port, the DIO data register corresponding to the port being used should be read and the value read from the register corresponds to the actual data on the DIO lines.

For example, to read DIO port B:

```
outp ( base + 41 , 0x00 ) ; // SET DIO PORT B DIRECTION AS INPUT ( DIRB = 0 )
value = inp ( base + 33 ) ; // READ THE DATA REGISTER TO GET THE DATA ON DIO LINES.
```

8. COUNTER/TIMER OPERATION

The FP-GPIO96 provides eight 32-bit counter/timers. The counter/timers can be used using the registers at offset 48-52 as shown in the table below.

Offset from BAR0	7	6	5	4	3	2	1	0
48	CTRD7-0							
49	CTRD15-8							
50	CTRD23-16							
51	CTRD31-24							
52	CTRN7-0							
53	CTRCMD3	CTRCMD2	CTRCMD1	CTRCMD0			CCD1	CCD0

CTRD31-0 Counter data to provide the counter duration

CTRN7-0 Counter number register (0 through 7)

CTRCMD3-0 Counter command bits

CCD1-0 Additional control bits for counter behavior

8.1 Counter/Timer Features and Configuration Options

Counter 0 can be used as a programmable A/D sampling clock. If not being used for A/D sampling, these counter/timers may be used for other functions. Counter/timer 1 is always available for user applications.

The inputs of the counter/timers are programmable, and the outputs may be routed to the I/O header under software control. The table below lists the key features of each counter/timer:

Counter/Timer Configuration Options

Counter	Input	Gate	Output
0	40MHz on-board 4MHz on-board External clock on DIOA0	Gate EN on DIOA1	Available on DIOC0 of the FeaturePak connector
1	40MHz on-board 4MHz on-board External clock on DIOA2	Gate EN on DIOA3	Available on DIOC1 of the FeaturePak connector
2	40MHz on-board 4MHz on-board External clock on DIOA4	Gate EN on DIOA5	Available on DIOC2 of the FeaturePak connector
3	40MHz on-board 4MHz on-board External clock on DIOA6	Gate EN on DIOA7	Available on DIOC3 of the FeaturePak connector
4	40MHz on-board 4MHz on-board External clock on DIOB0	Gate EN on DIOB1	Available on DIOC4 of the FeaturePak connector
5	40MHz on-board 4MHz on-board External clock on DIOB2	Gate EN on DIOB3	Available on DIOC5 of the FeaturePak connector
6	40MHz on-board 4MHz on-board External clock on DIOB4	Gate EN on DIOB5	Available on DIOC6 of the FeaturePak connector
7	40MHz on-board 4MHz on-board External clock on DIOB6	Gate EN on DIOB7	Available on DIOC7 of the FeaturePak connector

8.2 Counter/Timer Configuration

The counter/timer configuration is determined by the control register at BAR0 + 53 in the Counter Command Register as described in the register description. Note that the outputs of counter 1 can be routed to pin 157 under software control rather than being hardwired.

8.3 Counter/Timer Access and Programming

All the programming information regarding using the counter/timer of the FP-GPIO96 board is given in the Counter block register descriptions. The counter programming registers are available from offset 48 to 53 from the base address of BAR0.

NOTE: In the following examples, all of the register offset numbers are provided in decimal.

To program the counter timer, the following sequence of operations needs to be performed.

1. Write the counter number to the counter number register.

For example, to use Counter 1:

```
outp ( base + 52 , 1 );           // USING COUNTER 1.
```

- Write the count value to the counter data register. This value should be calculated based on the desired counter value as a divisor from the clock source used.

For example if the clock source for the counter is 50MHz clock and the desired counter value is 10KHz, the value that should be written to the counter data registers is $50,000,000/10,000 = 5000$ decimal or 0x1388.

```

outp ( base + 48 , 0x88 ) ;      // LSB of counter data
outp ( base + 49 , 0x13 ) ;     // MSB of counter data
outp ( base + 50, 0x00 ) ;     // UPPER BITS SHOULD BE 0
outp ( base + 51, 0x00 ) ;     // UPPER BITS SHOULD BE 0

```

- Write the counter command to the command register to execute the desired function.

For example, to enable counter 0

```
outp ( base + 3 , 0x41 ) ;      // enable and start counting on the selected counter.
```

More information on individual commands is provided in the sections below.

8.3.1 Counter/Timer commands

The counter/timers can be controlled using various commands shown in the table below.

CTRCMD3-0				Command	Control Bits		Action	Register Value
3	2	1	0		CCD 1	CCD 0		
0	0	0	0	Clear Counter.	X	X	-	0x00
0	0	0	1	Load the selected counter with data in CTRD32-0.	X	X	-	0x10
0	0	1	0	Select Count Direction.	X	1	Count up	0x21
					X	0	Count down	0x20
0	0	1	1	Enable / Disable External gate. When this command is selected for Counter 1, DIO pin AUX5 is reconfigured as an input and used for Counter 1 gate.	X	1	Enable Gating	0x31
					X	0	Disable Gating	0x30
0	1	0	0	Enable/Disable counting.	X	1	Enable Counting	0x41
					X	0	Disable Counting	0x40
0	1	0	1	Latch Selected counter.	X	X	-	0x50
0	1	1	0	Select Counter clock source.	0	X	Counter Input pin	0x60
					1	0	Internal CLK 50MHz	0x62
					1	1	Internal CLK 5MHz	0x63
1	1	1	1	Reset selected or both counters.	X	0	Reset selected counter	0xF0
					X	1	Reset both counters	0xF1

The programming details for each of the commands follow.

8.3.1.1 CLEAR COUNTER

To clear the counter, the following sequence should be used.

```
BYTE counter_number , counter_command ;  
outp ( base + 34 , counter_number ) ; // counter_number = 0 or 1  
counter_command = 0x00 ; // clear the selected counter.  
outp ( base + 35 , counter_command ) ; // issue the clear command
```

8.3.1.2 LOAD COUNTER

To load the counter, the command 0x10 should be used as below.

```
BYTE counter_number, counter_command ;  
// again using an example of loading the value of 0x1388 in counter 0.  
counter_number = 0 ; // or 1  
outp ( base + 34 , counter_number ) ;  
outp ( base + 30 , 0x88 ) ; // counter LSB  
outp ( base + 31 , 0x13 ) ; // counter MSB  
outp ( base + 35 , 0x10 ) ; // Load the counter selected
```

8.3.1.3 SELECT COUNT DIRECTION

The count direction for the selected counter can be set using the control bits CCD1-CCD0 as explained in the table above. The command to use is either 0x20 or 0x21 and the sequence is as below.

- To set the counter 0 in down count mode.

```
outp ( base + 52 , 0 ) ; // select counter 0  
outp ( base + 55 , 0x20 ) ; // down count direction
```
- To set the counter 1 in up count mode.

```
outp ( base + 52 , 1 ) ; // select counter 1  
outp ( base + 55 , 0x21 ) ; // down count direction
```

8.3.1.4 ENABLE/DISABLE GATING

Gating can be enabled on counter 1 only and the sequence to enable/disable gating is as below.

```
outp ( base + 52 , 1 ) ; // select counter 1  
outp ( base + 55 , 0x31 ) ; // enable gating
```

Alternatively to disable gating...

```
outp ( base + 55 , 0x30 ) ; // disable gating
```

8.3.1.5 ENABLE/DISABLE COUNTING

After the counter data is loaded in the counter register for the selected counter as shown in the section 14.4.2 of this document, the counter **MUST** be enabled to start the counter. After the counter has been started, it can be disabled using a different command as below.

// load the counter as in section 14.4.2. Do not change the counter select register in base + 52.

```
outp ( base + 55 , 0x41 ) ; // start the selected counter.
```

Alternatively to stop the counter...

```
outp ( base + 55 , 0x40 ) ; // stop the selected counter.
```

8.3.1.6 LATCH AND READ COUNTER

To read the counter value, it MUST be latched first otherwise the contents of the counter registers would not represent the current value of the counter.

The sequence to latch and read the counter 0 is as below.

```
BYTE ctr_byte0, ctr_byte1, ctr_byte2, ctr_byte3 ;
outp ( base + 52 , 0 ) ;           // select counter 0
outp ( base + 55 , 0x50 ) ;       // issue latch command
ctr_byte0 = inp ( base + 48 ) ;   // First byte of counter data
ctr_byte1 = inp ( base + 49 ) ;   // Second byte of counter data
ctr_byte2 = inp ( base + 50 ) ;   // Third byte of counter data
ctr_byte3 = inp ( base + 51 ) ;   // Fourth byte of counter data
```

8.3.1.7 SELECT COUNTER SOURCE

The counter source needs to be selected before actually starting a counter. As it can be seen from the table, there can be three different clock sources which the counter can use to performing counting operations. The clock source selection for the selected counter can be performed using only the corresponding command write to the counter command register.

```
outp ( base + 55 , 0x62 ) ;       // use 50 Mhz clock as source for the selected counter
```

Alternatively

```
outp ( base + 55 , 0x63 ) ;       // use 5 Mhz clock as source for the selected counter
```

Or

```
outp ( base + 55 , 0x60 ) ;       // use external clock source for counter clock
```

8.3.1.8 RESET COUNTER

The register map allows either resetting an individual counter or both the counters on the board. When the reset command is executed on a counter, the counter data resets to a value of 0.

To reset an individual counter (for example , counter 0)

```
outp ( base + 52 , 0 ) ;           // select counter 0
outp ( base + 55 , 0xF0 ) ;       // issue reset selected counter command
```

Alternatively, to reset both counters, the counter selection register at Base + 34 is ignored and the command to write is

```
outp ( base + 55 , 0xF1 ) ;       // issue reset counter command to both counters.
```

8.4 Timer interrupts

The FP-GPIO96 counters can be used to generate interrupts on the PCI bus at a regular programmable rate. To use the interrupts, the following should be done.

- Select the counter to use.
- Write the count value in the counter data register for the timing that is required.
- Enable the respective Timer interrupt enable bit. For timer 0 use T0INTEN bit and set it to 1. For timer 1, use T1INTEN bit and set it to 1. Please note that both the timers cannot be used at the same time to generate interrupts.
- Enable the respective counter/timer.
- Upon interrupt, check for the respective timer interrupt by reading the status bit T0INT for timer 0 and T1INT for timer 1.
- To generate the next interrupt, reset the respective timer interrupt request flip-flop by writing 1 to either T0INTCLR or T1INTCLR bits. If this bit is not reset in the interrupt service routine, the board will not generate any more interrupts.

9. PWM OPERATION

The FP-GPIO96 board has four PWM timers, each with a 24-bit resolution. The PWM circuit works very similarly to the counter/timer circuit and has similar register architecture.

The PWM circuit is controlled using the registers at offset 56 to 60 as shown in the table below.

Offset	7	6	5	4	3	2	1	0
56	PWMD7-0							
57	PWMD15-8							
59	PWMD23-16							
60	PWCMD3	PWCMD2	PWCMD1	PWCMD0	PWMCD	PWM2	PWM1	PWM0

PWMD23-0 24-bit PWM data. This is the PWM data for period as well as duty cycle.

PWMCMD3-0 PWM Command byte.

PWMCD Additional control bit for use by certain commands along with PWMCMD3-0.

PWM2-0 PWM circuit to use.

Each PWM consists of a pair of 24-bit down counters named C0 and C1. The C1 counter defines the duty cycle (active portion of the signal), and the C0 counter defines the period of the signal. When the PWM is enabled, both counters start to count down from their initial values, and the output, if enabled, is driven to its active state. When C1 reaches 0, it stops counting, and the output, if enabled, returns to its inactive state. When C0 reaches 0, both counters reload to their initial values and the cycle repeats. If C1 = 0 then duty cycle = 0. If C1 = C0, then duty cycle = 100% (the output should be glitch free).

The PWM command register has two fields, namely PWM Command in bits PWCMD3-0, and PWM circuit number in bits PWM2-0. The bit PWMCD is additional data for use by certain commands. The default setting for all parameters is 0 since the default / reset value for all registers in this circuit is 0.

If a PWM output is not enabled, its output is forced to the inactive state, which is defined as the opposite of the value selected with command 0010 (in PWMCMD3-0). The PWM may continue to run even though its output is disabled.

PWM outputs may be made available on Auxiliary DIO port's I/O pins DIOF0 to DIOF3 by writing a command value of 0101 to the PWM command register. When a PWM output is enabled, the corresponding pin on DIOFn is forced to output mode regardless of the DIRFn direction control bit. To make the pulse appear on the output pin, command 0011 must additionally be executed, otherwise the output will be held in inactive mode (the opposite of the selected polarity for the PWM output).

10. SPECIFICATIONS

Host Interface	
Interface type	PCI Express x1
Digital I/O	
Ports A, B, C, D, E, F, G, H, J, K, L, M	
Number of I/O lines	96
Compatibility	LVTTL
Pull-up / pull-down	Programmable
Input voltage	Low: 0.0V min, 0.8V max High: 2.0V min, 5.5V max
Input current	+/-340 μ A max
Output voltage	Low: 0.0V min, 0.4V max High: 2.4V min, 5.5V max
Output current	Ports A, B and D: 24mA per pin max, 200mA per port max Port C low: 24mA per pin max Port C high: -24mA per pin max Ports E and F: 32mA per pin max
Counters/Timers	
8 general purpose counters	32-bit up/down counter 50MHz, 5MHz, or external clock input
PWMs	
PWMs	Four independent 24-bit PWMs with user selectable clock at either 1MHz or 50MHz
General	
FeaturePak	Compliant, zero height expansion
Operating temperature	-40°C to +85°C (-40°F to +185°F)
Power Input	+3.3VDC
Power Consumption	330mW (typical without external load)
Weight	0.5 oz (14 g)
RoHS	Compliant