



Octavio Sales & Ordering Guide

Octavio embedded application servers are configurable to meet the needs of your particular application. Many aspects of the system are configurable and are specified at the time of order. Octavio systems are ordered using the nomenclature OCTAVIO-P-F-D-S-R where the following configurable system attributes are defined as follows.

- P = single board computer model
- F = flashdisk size
- D = optional integrated power supply
- S = enclosure height
- R = optional DIN rail adapter

The following sections describe these configuration options in more detail.

When requesting a quote for an Octavio system, please complete and return the **Octavio Quote Request Form** and **Octavio Configuration Request Form** found on pages 4 and 5 respectively of this Guide.

Part Number Description

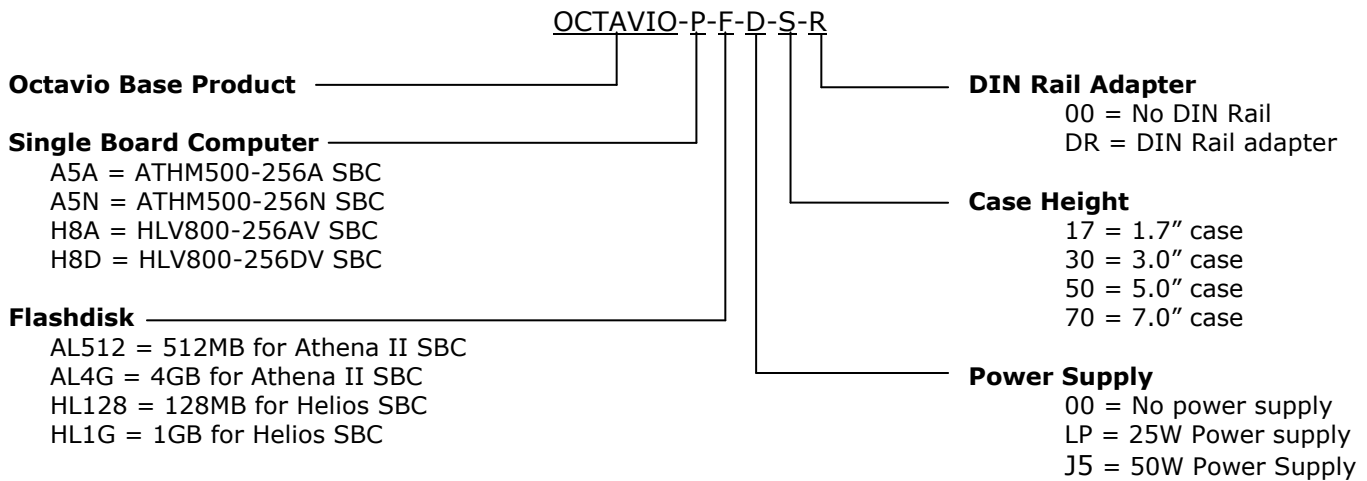

P: Single Board Computer Options

Several single board computer options exist that allow you to select the right balance of power and performance for your application, as well as whether to include the on-board data acquisition circuitry or not.

P: SBC Options	Description
A5A	Athena II SBC with 500MHz VIA Mark CPU and data acquisition
A5N	Athena II SBC with 500MHz VIA Mark CPU and no data acquisition
H8A	Helios SBC with 800MHz Vortex86DX CPU and data acquisition
H8D	Helios SBC with 800MHz Vortex86DX CPU and no data acquisition

F: Flashdisk Options

The size of the integrated flashdisk can be specified to give you enough room on-board for your application, thus eliminating the need for an additional hard drive. All flashdisks come with a Linux 2.6.23 bootable image and Diamond's Universal Driver 6.02 software pre-loaded.

F: Flashdisk Options	Description
AL512	512MB flashdisk for the Athena II SBC, pre-loaded with Linux 2.6.23
AL4G	4GB flashdisk for the Athena II SBC, pre-loaded with Linux 2.6.23
HL128	128MB flashdisk for the Helios SBC, pre-loaded with Linux 2.6.23
HL1G	1GB flashdisk for the Helios SBC, pre-loaded with Linux 2.6.23

D: Integrated Power Supply Options

An integrated power supply can be added to the Octavio system, allowing Octavio to operate in environments where +5V is not accessible. A 25W or 50W power supply can be selected. For more detailed information on these power supply modules, please visit our [25W Jupiter-MM-LP power supply](#) or [50W Jupiter-MM power supply](#) webpages. When a power supply is added to the system, the enclosure option S must be at least 3.0" in height.

D: Power Supply Options	Description
00	No integrated power supply
LP	25 watt integrated DC/DC power supply (requires a case height of 3.0" or greater)
J5	50 watt integrated DC/DC power supply (requires a case height of 3.0" or greater)

S: Case Height Options

The Octavio case comes in several different heights for I/O expansion. The standard case height is 1.7" for the basic system. If an integrated power supply is added, the case must be at least 3" in height.

S: Case Height Options	Description
17	1.7" case height
30	3.0" case height, accommodates up to 2 additional PC/104 cards
50	5.0" case height, accommodates up to 5 additional PC/104 cards
70	7.0" case height, accommodates up to 7 additional PC/104 cards

R: DIN Rail Adapter Options

A DIN rail adapter may be added to the Octavio system.

R: DIN Rail Options	Description
00	No DIN rail adapter
DR	DIN Rail Adapter Kit

Other System Options

Octavio systems come in standard, default configurations for various system aspects such as serial port and data acquisition configurations. Some of these may be configured to your specifications during manufacturing. The following options are available. When placing an order, please use the **Octavio Configuration Request Form** found on page 5 of this Guide, complete it and return to Diamond as instructed. Orders placed without an accompanying Octavio Configuration Request Form will be configured to the default settings.

Other System Options	Available Options (model dependent)
Serial Port Configuration	RS-232/422/485 selection IRQ Settings
Data Acquisition Configuration	Modes Polarity Interrupts
Console Redirection	Console redirection off/on

Custom Octavio Systems

Customized Octavio embedded application servers can also be created to perfectly match the requirements of your application. Customization options can include the following. Please [contact Diamond Systems](#) to request a custom Octavio quote and describe which items you would like configured into your Octavio system.

Customization Possibilities
Add an integrated 80GB hard disk drive
Integrate any of Diamond's PC/104 I/O modules (height of enclosure may change)
Substitute Windows CE for Linux operating system (Helios SBC models only)
Substitute QNX for Linux operating system (Athena II SBC models only)

Octavio Quote Request Form

Option	Description	Check one for each Option
P	SBC Options	
A5A	Athena II SBC with 500MHz VIA Mark CPU and data acquisition	<input type="checkbox"/>
A5N	Athena II SBC with 500MHz VIA Mark CPU and no data acquisition	<input type="checkbox"/>
H8A	Helios SBC with 800MHz Vortex86DX CPU and data acquisition	<input type="checkbox"/>
H8D	Helios SBC with 800MHz Vortex86DX CPU and no data acquisition	<input type="checkbox"/>
F	Flashdisk Options	
AL512	512MB flashdisk for the Athena II SBC with Linux pre-loaded	<input type="checkbox"/>
AL4G	4GB flashdisk for the Athena II SBC with Linux pre-loaded	<input type="checkbox"/>
HL128	128MB flashdisk for the Helios SBC with Linux pre-loaded	<input type="checkbox"/>
HL1G	1GB flashdisk for the Helios SBC with Linux pre-loaded	<input type="checkbox"/>
D	Power Supply Options	
00	No integrated power supply	<input type="checkbox"/>
LP	25 watt integrated DC/DC power supply (requires 3" case or larger)	<input type="checkbox"/>
J5	50 watt integrated DC/DC power supply (requires 3" case or larger)	<input type="checkbox"/>
S	Case Height Options	
17	1.7" case height	<input type="checkbox"/>
30	3.0" case height	<input type="checkbox"/>
50	5.0" case height	<input type="checkbox"/>
70	7.0" case height	<input type="checkbox"/>
R	DIN Rail Adapter Options	
00	No DIN rail adapter	<input type="checkbox"/>
DR	DIN Rail Adapter Kit	<input type="checkbox"/>

Quantity Requested

	Contact Information
Name	
Company	
Address	
Telephone #	
Fax #	
Email address	

If you want anything extra, please contact Technical Support at support@diamondsystems.com or call us at (650) 810-2500.

Please email this page to sales@diamondsystems.com or fax to (650) 618-2520.

Octavio Configuration Request Form

Please email this page to sales@diamondsystems.com or fax to (650) 618-2520.

Athena II	OCTAVIO-ATHM Options	
Serial Port Configuration	Options	Pick One
COM3 IRQ	IRQ 9 (default) IRQ 4	<input type="checkbox"/> <input type="checkbox"/>
COM4 IRQ	IRQ 15 (default) IRQ 6	<input type="checkbox"/> <input type="checkbox"/>
COM3 RS-232/485	RS-232 (default) RS-485	<input type="checkbox"/> <input type="checkbox"/>
COM4 RS-232/485	RS-232 (default) RS-485	<input type="checkbox"/> <input type="checkbox"/>
Data Acquisition Configuration		
A/D Mode	A/D Single Ended (default) A/D differential	<input type="checkbox"/> <input type="checkbox"/>
A/D Polarity	A/D Bipolar (default) A/D Unipolar	<input type="checkbox"/> <input type="checkbox"/>
D/A Polarity	D/A Bipolar (default) D/A Unipolar	<input type="checkbox"/> <input type="checkbox"/>
Console Redirection Configuration		
Console Redirection	Off (default) On	<input type="checkbox"/> <input type="checkbox"/>

Helios	OCTAVIO-HLV Options	
Serial Port Configuration	Options	Pick One
COM1 RS-232/422/485	RS-232 (default) RS-422 RS-485	<input type="checkbox"/> <input type="checkbox"/> <input type="checkbox"/>
COM2 RS-232/422/485	RS-232 (default) RS-422 RS-485	<input type="checkbox"/> <input type="checkbox"/> <input type="checkbox"/>
Data Acquisition Configuration		
DAQ Interrupts Enabled	On (default) Off	<input type="checkbox"/> <input type="checkbox"/>
DAQ Interrupt IRQ	IRQ5 (default) IRQ6	<input type="checkbox"/> <input type="checkbox"/>
Console Redirection Configuration		
Console Redirection	Off (default) On	<input type="checkbox"/> <input type="checkbox"/>

	Contact Information
Name	
Company	
Address	
Telephone #	
Fax #	
Email address	

Please email this page to sales@diamondsystems.com or fax to (650) 618-2520.